

IMPORTANT: WIRE CONNECTION TO TERMINAL BLOCK ON AIRHANDLER MUST BE CONNECTED AS SHOWN.

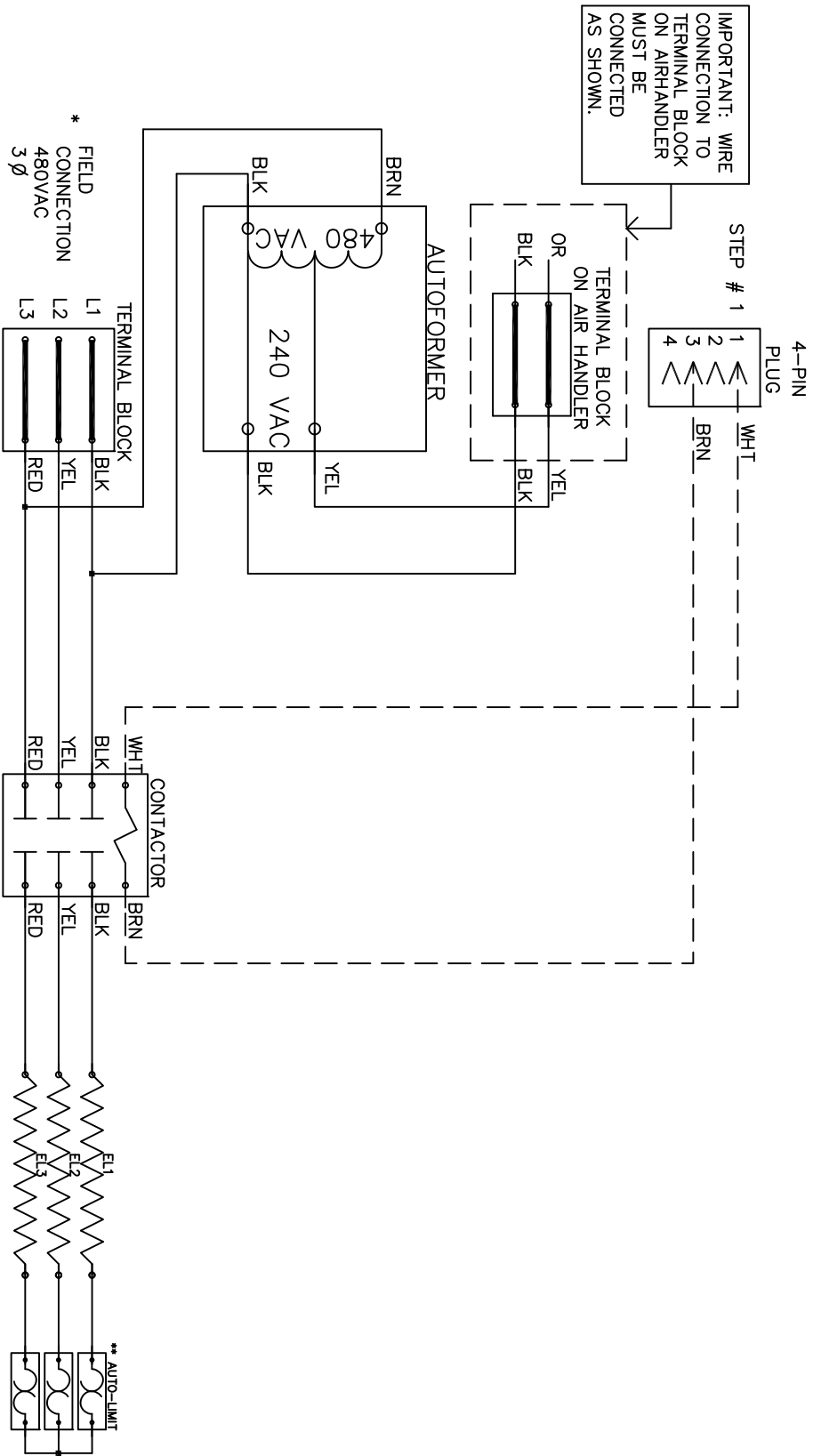

NOTE :

- * Power supply wiring per NEC & Local Codes. Suitable for at least 75°C. Use copper conductor wiring only.
- ** Replace Auto-Reset with Therm-O-Disc type L-150/L-333..
- 24VAC, Class 2 power source must not exceed 26.4VAC under any primary input voltage condition per UL/NEC.

Model _____
 Serial # _____
 Tag - _____
 Kilowatts _____
 Volts-Ph-Hz _____
 Control Volts _____
 Steps _____
 Heater Amps _____
 Circuit Breakers _____

WRX1505A

Rev. by : M. REEVES
 Date : 02/27/15

WARREN TECHNOLOGY

Control Wiring _____
 Power Wiring _____
 Field Wiring _____