

IMPORTANT: WIRE CONNECTION TO TERMINAL BLOCK ON AIRHANDLER MUST BE CONNECTED AS SHOWN.

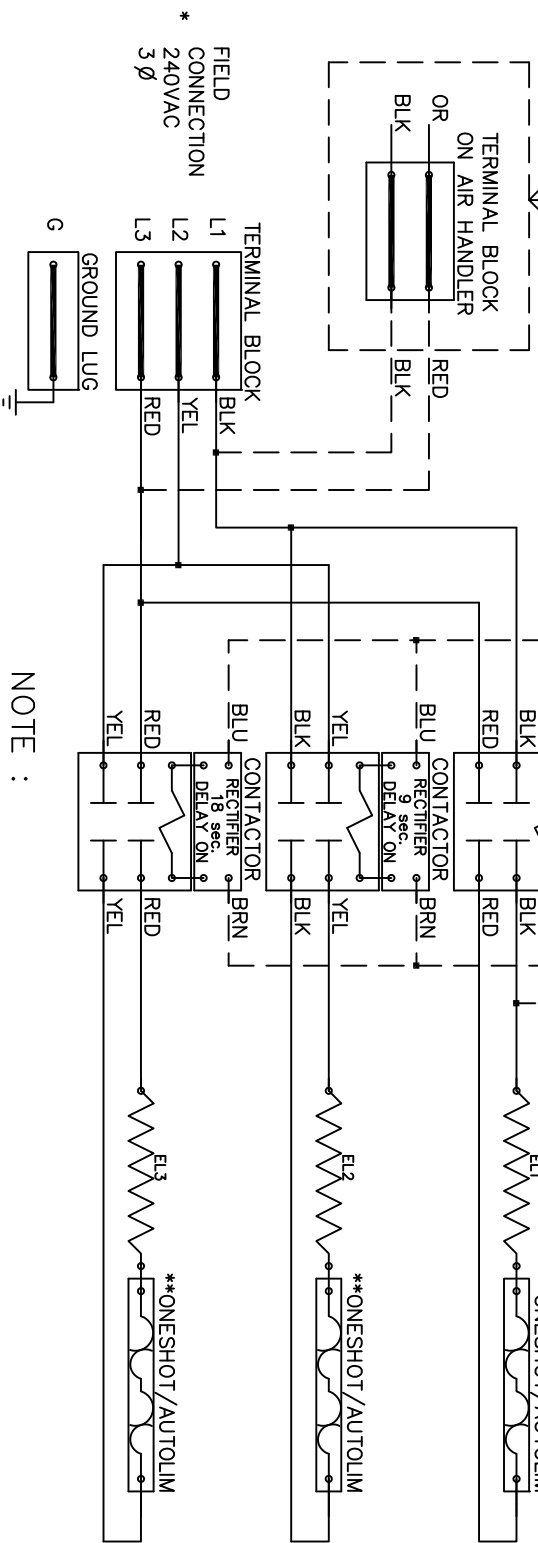

NOTE :

- * Power supply wiring per NEC & Local Codes. Suitable for at least 75°C. Use copper conductor wiring only.
 - ** Replace One Shot/Auto-Reset with Therm-O-Disc type L150F-333F
 - *** Relays utilize 22-28VDC coils with AC to DC rectifiers. Do not use relay without rectifier.
- 24VAC, Class 2 power source must not exceed 26.4VAC under any primary input voltage condition per UL/NEC.

Model _____ WRX-1504

Serial # _____

Tag - _____

Kilowatts _____ 14.4

Volts-Ph-Hz _____ 240/3/60

Control Volts _____ 24.0

Steps _____ 2

Heater Amps _____ 34.64

Circuit Breakers _____ N/A

Control Wiring _____

Power Wiring _____

Field Wiring _____