

WRX-1502BX

4-PIN
PLUG

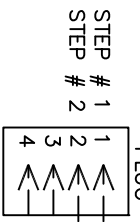

IMPORTANT: WIRE CONNECTION TO TERMINAL BLOCK ON AIRHANDLER MUST BE CONNECTED AS SHOWN.

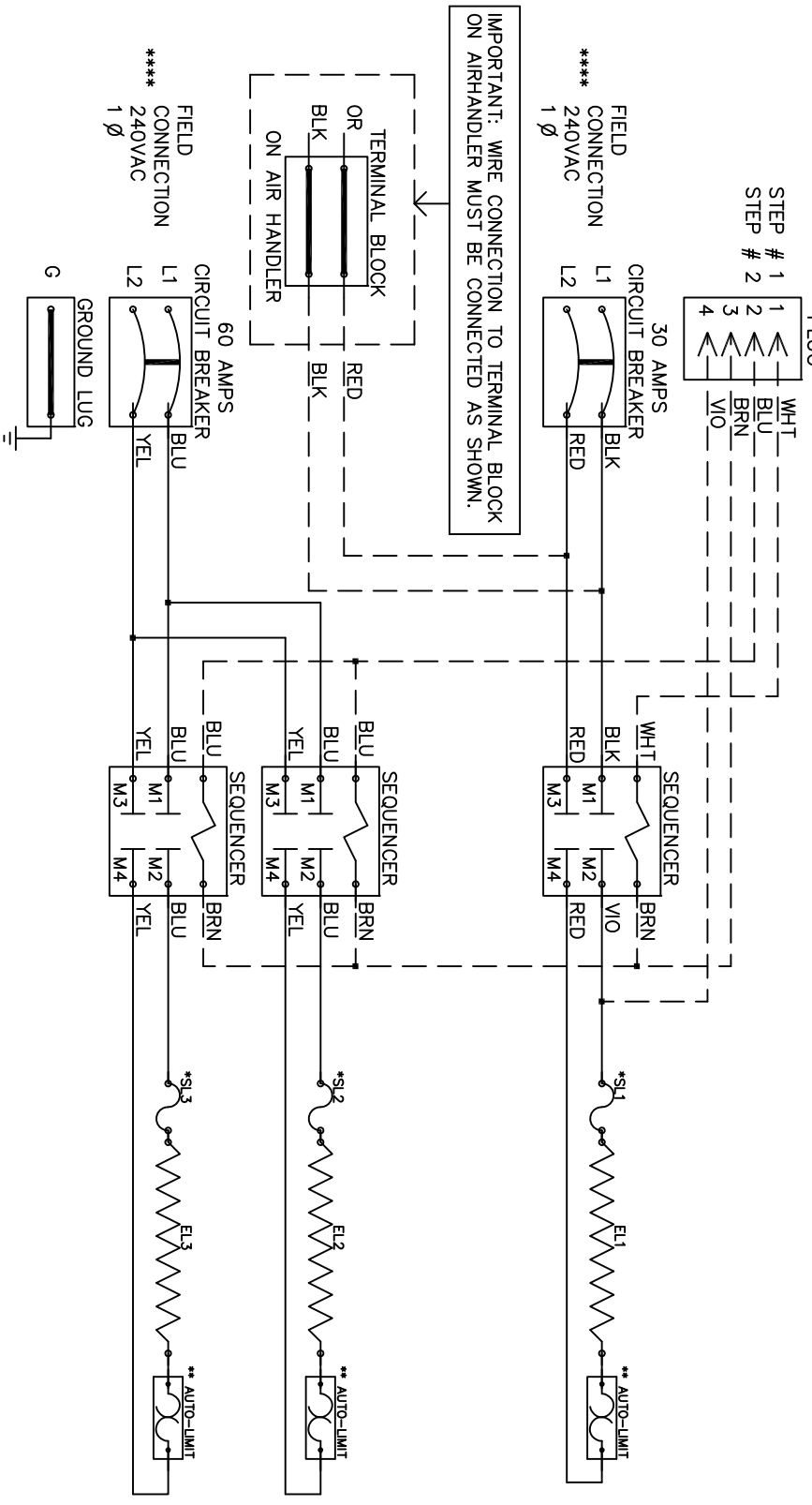

Model _____
 Serial # _____
 Tag - _____
 Kilowatts _____
 Volts-Ph-Hz _____
 Control Volts _____
 Steps _____
 Heater Amps _____
 Circuit Breakers _____

NOTE :

- * Replace "Service Loop" with SL075B
- ** Replace Auto-Reset with Therm-O-Disc type 60TX11-L165.
- *** 24VAC, Class 2 power source must not exceed 26.4VAC under any primary input voltage condition per UL/NEC.
- **** Power supply wiring per NEC & Local Codes. Suitable for at least 75°C.

Use copper conductor wiring only.

Control Wiring _____
 Power Wiring _____
 Field Wiring _____