

WGM — 0504

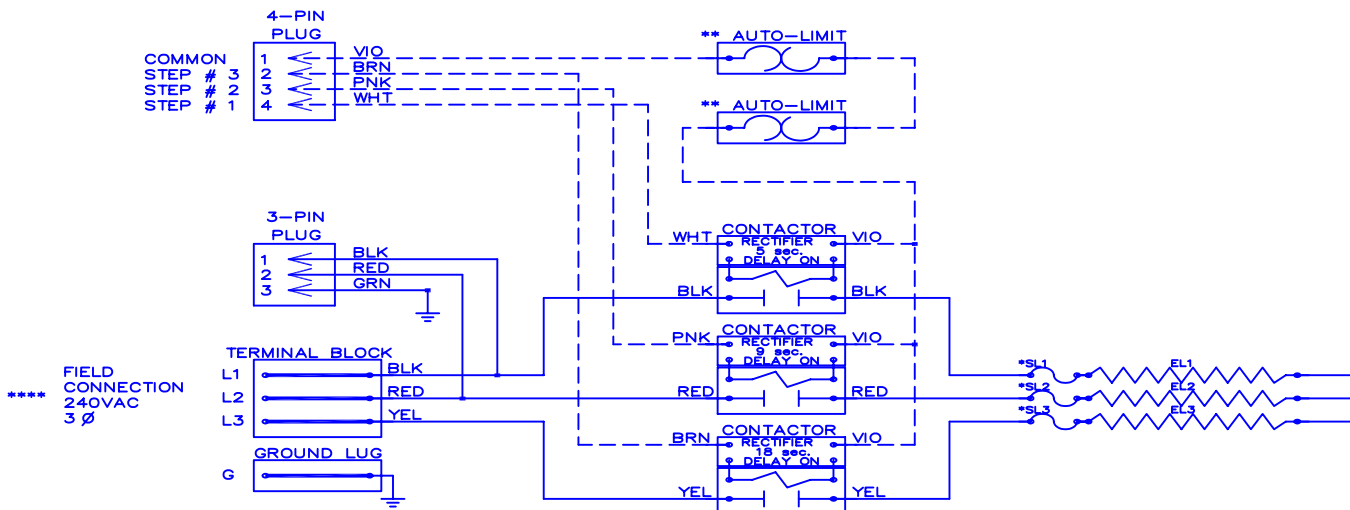

FIELD CONNECTION
240VAC
3 ϕ

Model	_____
Serial #	_____
Tag	_____
Kilowatts	4.80
Volts-Ph-Hz	240/3Y/60
Control Volts	24.0
Steps	3
Heater Amps	11.6

NOTE :

- * Replace "Service Loop" with SL 6040-063
- ** Replace Auto-Reset with Therm-O-Disc type 60TX11-L165.
- *** Relays utilize 22VDC coils with AC to DC rectifiers. Do not use relay without rectifier.

24VAC, Class 2 power source must not exceed 26.4VAC under any primary input voltage condition per UL/NEC.
 **** Power supply wiring per NEC & Local Codes. Suitable for at least 75°C.
 Use copper conductor wiring only.

Control Wiring _____
 Power Wiring _____
 Field Wiring _____

WGM0504

Rev. by : M. REEVES
 Date : 08/16/11

WARREN TECHNOLOGY