

WARREN ELECTRIC HEATERS WSRM SERIES	INSTALLATION INSTRUCTIONS Date: 07/25/12	CARRIER / BRYANT 40RM 007-012 40RMQ 008- 012 / 40RMS 008 - 012 40RUA 07 - 12 / 40RUS 08-12 524A 072-120 PACKAGED AIR HANDLERS
-------------------------------------------------------	------------------------------------------------------------	-----------------------------------------------------------------------------------------------------------------------------------------------------

GENERAL

This electric heater series is engineered and designed, to be installed in the Carrier 40RM(Q)(S) 007 - 012, 40RU(A)(U) 07 - 12, and BRYANT 524A 072 - 120 packaged air handlers. Before proceeding, check the heater label for correct voltage and KW requirements. The electrical heat accessory can be used in vertical or horizontal airflow applications.

Installation and servicing of this equipment should only be performed by trained and qualified personnel. Before proceeding with the heater installation, inspect thoroughly for shipping damage. Notify the shipper immediately if any damage is found. Check all porcelain insulators for breakage and inspect heater element wire to see that none have been deformed. Clean all dirt, dust and moisture from equipment. **Check for proper clearances of live parts, between phases, and to ground.** Make sure that all required barriers are in place. Check conductors run in multiple to insure that they are properly wired. Refer to installation instructions for complete unit installation details. **Verify that all elements are properly secure in their ceramic holders.**

WARNING

Before performing service or maintenance operations on system, turn off all main power switches. There may be more than one disconnect. Turn off accessory heater power switch if applicable. Electrical shock can cause personal injury. **TAG DISCONNECT SWITCH(ES) WITH A SUITABLE WARNING LABEL.**

HEATER INSTALLATION

1. Refer to base unit installation instruction as required.
2. Remove screws surrounding the blower outlets. Do not install the duct flanges shipped with the unit.
3. Install heater assembly directly over the supply duct of the air handler. Position the heater control box on the right hand side of the air handler (see fig. 1).
4. Heater elements should be located above each fan discharge opening. Heater baffle should be aligned with the blower assembly and should be inspected to ensure efficient blow-thru operation.
5. Secure heater flanges with sheetmetal screws to the air handler unit (see fig.1).
6. Remove the heater control box cover to obtain access to additional heater mounting holes and for electrical connections.
7. Size the supply duct according to the discharge opening in the top of the heater and connect the ductwork with field supplied screws. The air duct system should be designed and installed in accordance with the standards of the national protection association (Pamphlet 90A or 90B). A flexible duct connector is recommended to prevent transmission of vibration. Use suitable gaskets to ensure weather tight and air tight seal. If flexible duct is used, insert a sheet metal sleeve inside the duct. Heat resistant duct connector (or sheetmetal sleeve) must extend 24-in. from the unit connection flanges into the duct work.

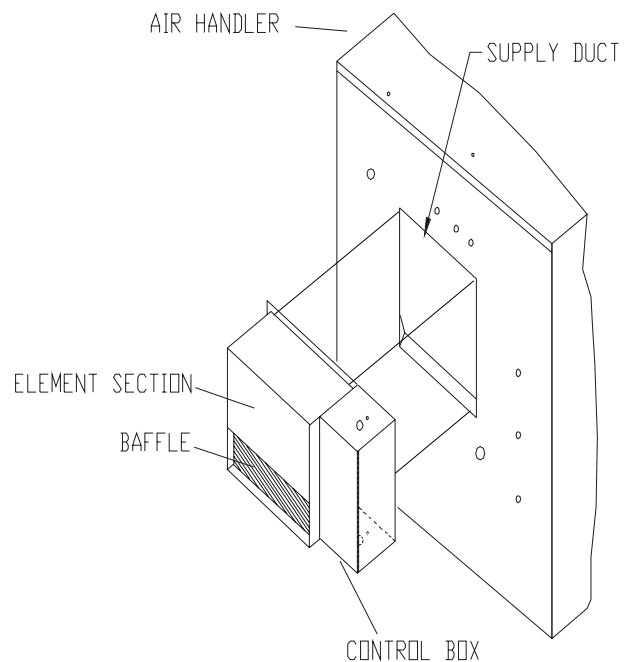

Fig. 1

ELECTRICAL CONNECTIONS

1. All electrical connections, wire sizes and type and conduit sizes shall meet the National Electric Code, State and Local Codes. Main power supply, minimum wire sizes, circuits, fusing, etc. are shown on schematic wiring diagrams. **NOTE:** Use copper wire only.
2. Refer to base unit instructions for recommended wiring procedures.
3. All connections should be made inside of the heater control box. Route supply wires from fused disconnect (field supplied) through conduit knockouts to the heater kit and connect to the terminal block inside the heater control box. Heater design allows for single point electrical connection of the indoor fan.
4. **Low voltage connections.** Connect low voltage control wires as shown on wiring diagram. Refer to air handler installation manual for wiring options for the thermostat.
5. Check wiring diagram supplied with heater for specific connections and information .
6. Be sure that all electrical terminal connectors, clamps, screws, etc. are tight before proceeding.
7. Check operation as described in start-up section.

START-UP AND CHECK-OUT

CAUTION: Before proceeding, verify that all wiring is correct per factory approved schematic. Notify factory immediately of any discrepancies.

1. Refer to base unit installation instructions as required.
2. Check for loose terminal connections.
3. Check that all fuse and circuit breaker short circuit interrupting ratings are adequate.
4. Turn on unit and heater power.
5. Set thermostat to call for heat.
6. Check operation of heater.
7. Check that air flow across heater is at or above minimum recommended fan speed.

IMPORTANT: The minimum air velocity as shown on the wiring diagram is required and must be even across the face of the heater.

8. Verify air handler (or package unit) evaporator fan motor amperage against rated amperage, both in cooling and heating modes to check sequence of control operation
9. Any modification or repairs to this equipment without written permission from the factory will be done at the installer's own risk and expense.

ELECTRIC HEATER PACKAGE CONTENTS

1. Heater assembly
2. Installation Instructions
3. Installer label
4. Wiring diagram