

**IMPORTANT: WIRE CONNECTION TO TERMINAL BLOCK ON AIRHANDLER MUST BE CONNECTED AS SHOWN.**

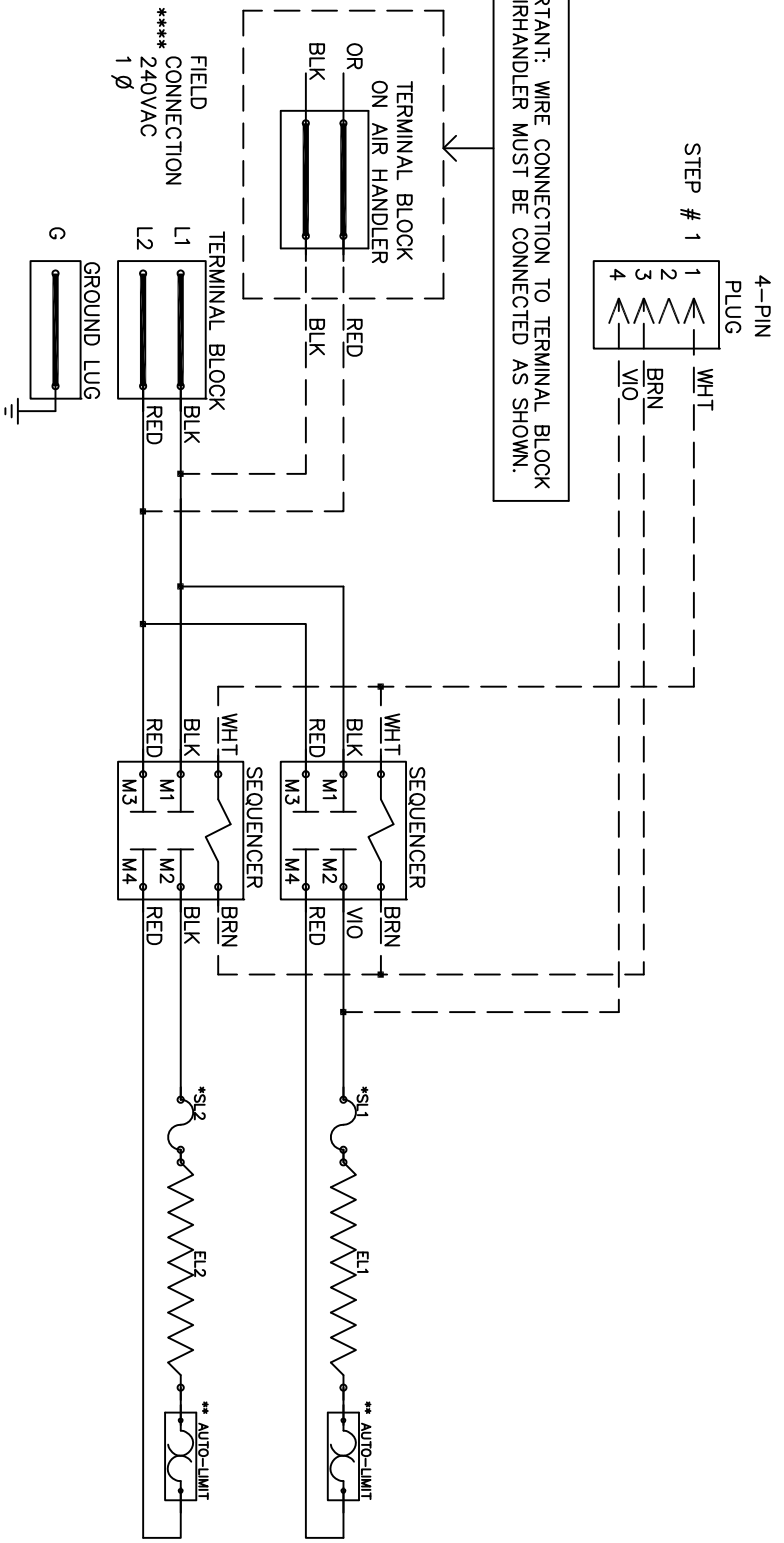

Model \_\_\_\_\_  
 Serial # \_\_\_\_\_  
 Tag - \_\_\_\_\_  
 Kilowatts \_\_\_\_\_  
 Volts-Ph-Hz \_\_\_\_\_  
 Control Volts \_\_\_\_\_  
 Steps \_\_\_\_\_  
 Heater Amps \_\_\_\_\_  
 Circuit Breakers \_\_\_\_\_

**NOTE :**

- \* Replace "Service Loop" with SLO75B
- \*\* Replace Auto-Reset with Therm-O-Disc type 60TX11-L165.
- \*\*\* 24VAC, Class 2 power source must not exceed 26.4VAC under any primary input voltage condition per UL/NEC.
- \*\*\*\* Power supply wiring per NEC & Local Codes. Suitable for at least 75°C.

Use copper conductor wiring only.

Control Wiring \_\_\_\_\_  
 Power Wiring \_\_\_\_\_  
 Field Wiring \_\_\_\_\_

WRX1002X