

WGS-0751H / 1002H

USE PLUG ADAPTOR ON: 50CE/50CR/50DT/
50DU/50XL/50XT/604C/607B/607D/704C/
707B/704C/707B/707D.

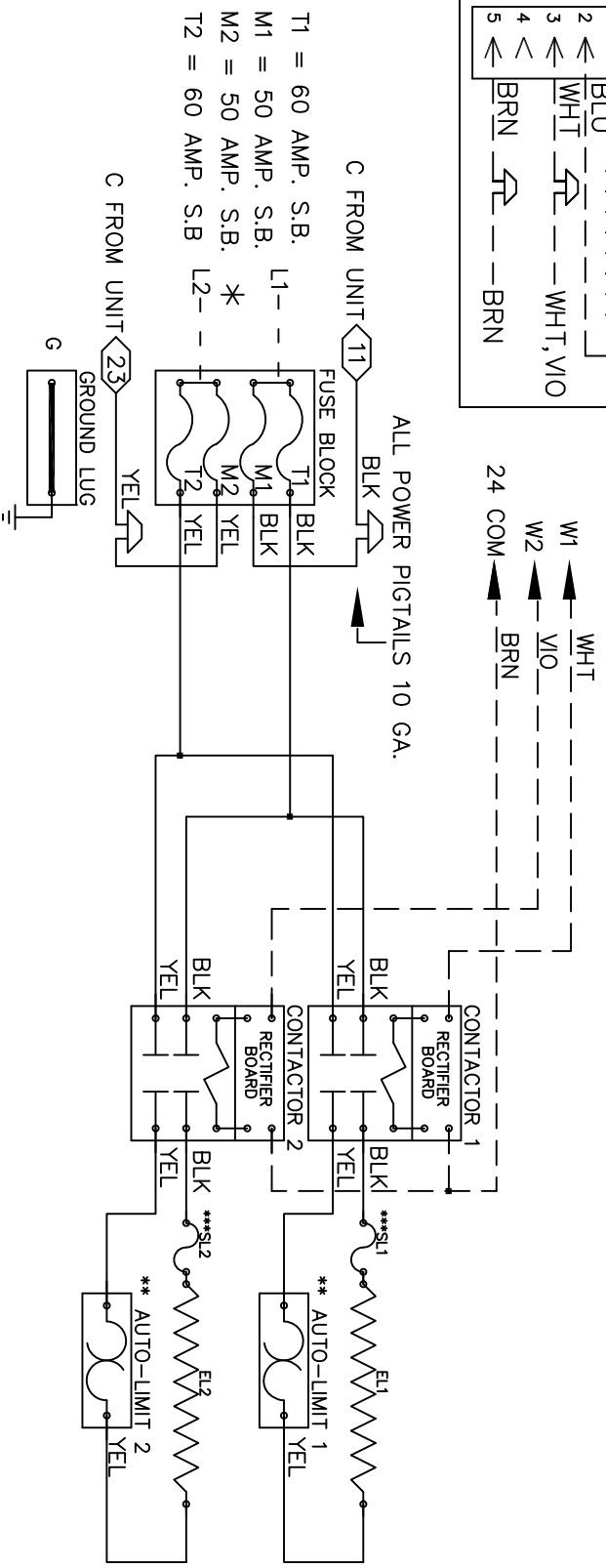
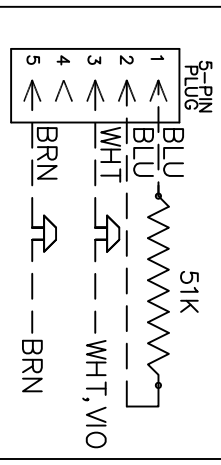

NOTE :

- * Power supply wiring per NEC & Local Codes. Suitable for at least 75° C
- Use copper conductor wiring only.
- Field wire, NEC Class 1
- ** Replace Auto-Reset with Therm-O-Disc type 60TX11-L165
- *** Replace Service-Loop with SL075B
- CAUTION-RELAYS UTILIZE 22VDC COILS WITH AC TO DC RECTIFIERS. DO NOT USE RELAY WITHOUT RECTIFIER
- REPLACE WITH FACTORY AUTHORIZED PARTS ONLY.
- 24VAC, Class 2 power source must not exceed 26.4VAC under any primary input voltage condition per U.L./NEC.

Model _____
 Serial # _____
 Tag - _____
 Kilowatts 7.5/10.0
 Volts-Ph-Hz 208/240 /1/ 60
 Control Volts 24.0
 Steps 2
 Heater Amps 36.1/41.7
 Heater Fuses See chart above

WGS-0751H/1002H

Control Wiring _____
 Power Wiring _____
 Field Wiring _____

Rev. by : M. REEVES
 Effective Date: 02/27/15

WARREN TECHNOLOGY

WGS1002H