

<p><b>Warren Electric Heater Model WSK Series</b></p>	<p><b>INSTALLATION AND OPERATING INSTRUCTIONS</b></p>  <p><b>WARREN</b> TECHNOLOGY Date: 9-25-08</p>	<p><b>Rheem/Ruud Self-Contained Air Conditioners Package Heat Pumps</b></p> <p>RSMA/RSKA/RQMA/RQKA 018-036 USMA/USKA/UQMA/UQKA 018-042 RSNA/RSNL/RSPL 024-060 RQNA/RQNL/RQPL 024-048</p>
---	---	--

## GENERAL

This Warren Technology electric heater is engineered, designed, and A.R.L. approved to be installed in the Rheem RSMA/RSKA/RQMA/RQKA 018-036, Ruud USMA/USKA/UQMA/UQKA 018-036 and Rheem/Ruud RSNA/RSNL/RSPL 024-060, RQNA/RQNL/RQPL 024-048 self contained air conditioners and package heat pumps. Before proceeding, check the heater label for correct voltage and KW requirements.

Installation and servicing of this equipment should only be performed by trained and qualified personnel. Before proceeding with the heater installation, inspect thoroughly for shipping damage. Notify the shipper immediately if any damage is found. Check all porcelain insulators for breakage and inspect heater element wire to see that none have been deformed. Clean all dirt, dust, and moisture from equipment. Check for proper clearances of live parts, between phases, and to ground. Make sure that all required barriers are in place. Check conductors run in multiple to insure that they are properly wired. Refer to installation instructions for complete unit installation details.

### **WARNING**

Before performing service or maintenance operations on system, turn off all main power switches. There may be more than one disconnect. Turn off accessory heater power switch if applicable. Electrical shock can cause personal injury. **TAG DISCONNECT SWITCH(ES) WITH A SUITABLE WARNING LABEL.**

## HEATER INSTALLATION

### **INSTALL HEATER AS FOLLOWS:**

1. Refer to the base unit installation instructions as required.
2. Remove control access panel of unit.
3. Remove blank cover plate.
4. Slide heater assembly into blower section through the access opening. Secure heater into place with screws from cover plate. Connect modular plug from the heater assembly to the unit base plug.
5. Remove the conduit knockout in unit cabinet for electrical connections. Install the appropriate size conduit connector.
6. Connect the field wires to the terminal block or fuse block on the electric heater kit. Connect the ground wire to the ground lug on the heater kit.
7. The pigtail wires in the electric heat box must be connected to the contactor in the control box and are protected by internal fuses in the hinged fuse box on the heater kit. See installer label for correct fuse sizing

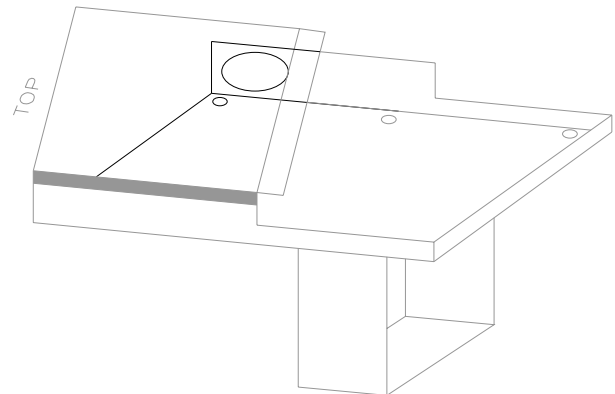

N:\WORKSHEETS-NEW\RHEEM 9-25-08

## **WARNING**

Before performing service or maintenance operations on system, turn off all main power switches. There may be more than one disconnect. Turn off accessory heater power switch if applicable. Electrical shock can cause personal injury. **TAG DISCONNECT SWITCH(ES) WITH A SUITABLE WARNING LABEL.**

## **ELECTRICAL CONNECTIONS**

### **CONNECT HEATER AS FOLLOWS:**

1. All electrical connections, wire sizes and type of conduit sizes shall meet the National Electric Code, State and Local Codes. Main power supply, Minimum wire sizes, circuits, fusing, etc. is shown on schematic wiring diagrams. **NOTE: Use copper wire only.**
2. Refer to base unit instructions for recommended wiring procedures.
3. Connect heater plug to corresponding plug in the air handler.
4. Separate all wires from incoming power leads.
5. Be sure that all electrical terminal connections, clamps, screws, etc. are tight before proceeding.
6. Check wiring supplied with heater for specific connections and information.
7. Check operation as described in start-up section.

## **START-UP and CHECK-OUT**

**CAUTION:** Before proceeding, verify that all wiring is correct per factory approved schematic. Notify factory immediately of any discrepancies.

1. Refer to base unit installation instructions as required.
2. Check for loose terminal connections.
3. Check that all fuses ratings are adequate.
4. Turn on unit and heater power.
5. Set thermostat to call for heat.
6. Check operation of heater.
7. Check that air flow across heater is at or above minimum recommended fan speed. Adjust as required.
8. Any modifications or repairs to this equipment without written permission from the factory will be done at the installer's own risk and expense.

## **SERVICE**

**Fuses** - Open fuse links will interrupt power to the unit. *Replace fuses and check for cause of failure, restart.*

**Limit Switch** - Malfunction prevents heating element(s) from being energized. *Replace switch if malfunction occurs.*

**Sequencers** - Malfunction will not allow heater to come on or shut off. *Replace faulty sequencers. Do not attempt to replace coil or dress contacts.*

## **ELECTRIC HEATER PACKAGE CONTENTS**

1. Heater assembly
2. Installation Instructions
3. Installer label
4. Schematic