

Warren Electric
Heater Model
WLZ Series

INSTALLATION AND OPERATING INSTRUCTIONS



**LENNOX BLOWER
COIL UNITS**
CB29M, CB30M, CB30U,
CB31MV, CBX32MV, CBX32M
Series

GENERAL

This Warren Technology electric heater is engineered, designed, and approved to be installed in the Lennox ELITE CB29M, CB30M, CB30U, CB31MV, CBX32MV, CBX32M Series, multi position blower coil units. Before proceeding, check the heater label for correct voltage and KW requirements.

Installation and servicing of this equipment should only be performed by trained and qualified personnel. Before proceeding with the heater installation, inspect thoroughly for shipping damage. Notify the shipper immediately if any damage is found. Check all porcelain insulators for breakage and inspect heater element wire to see that none have been deformed. Clean all dirt, dust, and moisture from equipment. Check for proper clearances of live parts, between phases, and to ground. Make sure that all required barriers are in place. Check conductors run in multiple to insure that they are properly wired. Refer to installation instructions for complete unit installation details. **Make sure that all elements are properly secured in their ceramic holders.**

WARNING

Before performing service or maintenance operations on system, turn off all main power switches. There may be more than one disconnect. Turn off accessory heater power switch if applicable. Electrical shock can cause personal injury. **TAG DISCONNECT SWITCH(ES) WITH A SUITABLE WARNING LABEL.**

HEATER INSTALLATION

INSTALL HEATER AS FOLLOWS:

1. Refer to the base unit installation instructions as required.
2. Remove blower section access panel of air handler.
3. Remove electric heat patch plate inside blower coil unit. For units with two knockouts in patch plate, the entire patch plate should be removed to allow for installation of 20KW, 25KW, and 30 KW sized heaters. Use diagonal cutters to cut through sheet metals. Discard unused patch plate.
4. Carefully slide heater assembly into blower section through the air handler access opening. Secure heater into place with screws provided.
5. Remove the conduit knockout in blower cabinet for electrical connections. Install the appropriate size conduit connector. Refer to heater schematic provided.

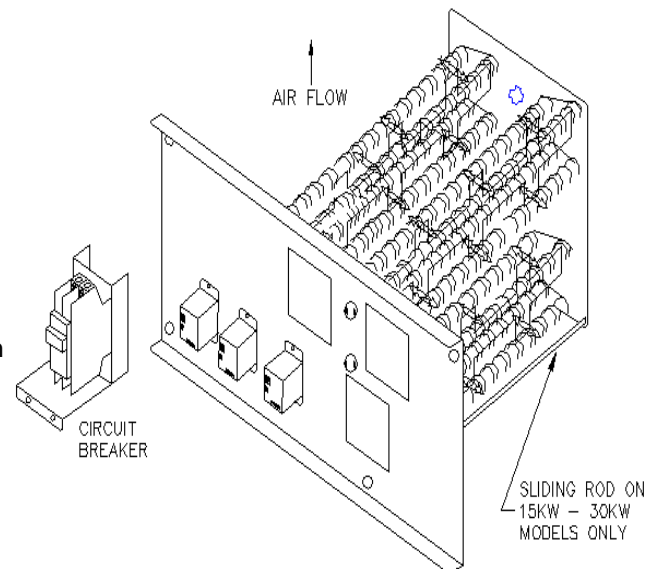

HEATERS WITH CIRCUIT BREAKERS:

NOTE: IN DOWNFLOW APPLICATIONS, CIRCUIT BREAKERS MUST BE ROTATED 180° TO THE UP POSITION.

1. Install circuit breakers to blower deck flange using screws provided.
2. Remove circuit breaker knockout(s) in unit access panel as required. Cut out insulation in opening. Mount circuit breaker with screws using mounting holes provided.
3. Install breaker seal over the circuit breaker unit opening on the blower access panel using screws provided (2 types of circuit breaker seals are provided, choose the appropriately sized circuit breaker seal).

WARNING

Before performing service or maintenance operations on system, turn off all main power switches. There may be more than one disconnect. Turn off accessory heater power switch if applicable. Electrical shock can cause personal injury. **TAG DISCONNECT SWITCH(ES) WITH A SUITABLE WARNING LABEL.**

ELECTRICAL CONNECTIONS

CONNECT HEATER AS FOLLOWS:

1. All electrical connections, wire sizes and type of conduit sizes shall meet the National Electric Code, State and Local Codes. Main power supply, Minimum wire sizes, circuits, fusing, etc. is shown on schematic wiring diagrams. **NOTE: Use copper wire only.**
2. Refer to base unit instructions for recommended wiring procedures.
3. Connect heater plug to corresponding plug in the air handler.
4. Separate all wires from incoming power leads.
5. Blower unit is wired for single stage heat. For multiple stage heaters remove jumper wires between "R" and "W2" and "W3" accordingly. Also the minimum blower setting for each blower size with any heat section in any application is **HIGH**. Refer to base unit instructions for blower speed adjustment.
6. Be sure that all electrical terminal connections, clamps, screws, etc. are tight before proceeding.
7. Check wiring supplied with heater for specific connections and information.
8. Check operation as described in start-up section. Affix Warren installer label to equipment access door.

START-UP and CHECK-OUT

CAUTION: Before proceeding, verify that all wiring is correct per factory approved schematic. Notify factory immediately of any discrepancies.

1. Refer to base unit installation instructions as required.
2. Check for loose terminal connections.
3. Check that all circuit breaker short circuit interrupting ratings are adequate.
4. Turn on unit and heater power. Verify electrical readings per schematic.
5. Set thermostat to call for heat.
6. Check operation of heater.
7. Check that air flow across heater is at or above minimum recommended fan speed. Adjust as required.
8. Any modifications or repairs to this equipment without written permission from the factory will be done at the installer's own risk and expense.

SERVICE

Circuit Breakers - Malfunction will interrupt power to the unit. *Check for cause of failure, restart.*

Limit Switch - Malfunction prevents heating element(s) from being energized. *Replace switch if malfunction occurs.*

Contactors - Malfunction will not allow heater to come on or shut off. *Replace faulty contactors. Do not attempt to replace coil or dress contacts.*

ELECTRIC HEATER PACKAGE CONTENTS

1. Heater assembly
2. Installation Instructions
3. Installer label
4. Schematic
5. Screws (6)