

<p align="center">208/240, 1 phase Accessory Electric Heaters for Package Air Conditioning and Package Heat Pumps 1½ thru 5 tons To Fit: Unit Models 50GS/GL/VL(-A) 018-060, 50XT(-A)/XL/DU/DT/CR 024-060 50CE/GX/JS/JX/JZ/SD/SZ/XZ 024-060 701A 018-060, 607B, 707B/D 024-060 702A/601A/602A/604A/C, 704A/C, D(-A) 024-060 PA1P-B 018-060, PA2P-B/PH1P-B/PH2P-B PA3PN/PH3PN 024-060 50EZ(-A)/VT(-A) 24-60 604D(-A)/607C(-A)/607D(-A) 24-60</p>	<p align="center">DUAL POINT INSTALLATION INSTRUCTIONS</p> <p align="center">DATE: 8-9-2010</p>	<p align="center">208/240/480, 3 phase Accessory Electric Heaters for Package Air Conditioning and Package Heat Pumps 2½ thru 5 tons To Fit: Unit Models 50CR/SZ/XT/DU/DT/CR/CE/XZ 024-060 50GS/GL/GX/JS/JX/JZ 030-060 604A/C/704C/607B/707B/D 024-060 701A, 702A/601A/602A 030-060 PA1P-B 030-060; 704D(-A) 024-060 PA2P-B/PH1P-B/PH2P-B 030-060 50EZ(-A)/VT(-A) 24-60 604D(-A)/607C(-A)/607D(-A) 24-60</p>
---	---	--

GENERAL

This electric heater series is engineered, designed, and listed to be installed in the Carrier 50GS/GL/VL(-A) 018-060, 50XT(-A)/XL/CE/CR/DT/DU/EZ(-A)GX/JS/JX/JZ/SD/SZ/VT(-A)/XZ 024-060, Bryant 701A 018-060, 702A/601A/602A 024-060, 604A/C/D(-A), 607B/D, 607C/D(-A), 704A/C, D(-A), 707B/D and Payne PA1P-B 018-060, PA2P-B/PH1P-B/PH2P-B 024-060, PA3PN/PH3PN 024-060 208/240 volt, single phase as well as Carrier 50CR/SZ/XT/XL/DU/DT/CR/CE/XZ 024-060, 50GS/GL/GX/JS/JX/JZ 030-060, Bryant 604A/C, 607B/D, 707B/D 024-060, 701A/702A/601A/602A 030-060, and Payne PA1P-B/PA2P-B/PH1P-B/PH2P-B 030-060; 208/240/480 volt, three phase series packaged air conditioners and heat pumps.

Before proceeding, verify the heater label for correct voltage and KW requirements.

Installation and servicing of this equipment should only be performed by trained and qualified personnel. Before proceeding with the heater installation, inspect thoroughly for shipping damage. Notify the shipper immediately if any damage is found. Check all porcelain insulators for breakage and inspect heater element wire to see that none have been deformed. Clean all dirt, dust and moisture from equipment. Check for proper clearances of line parts, between phases, and to ground. Make sure that all required barriers are in place. Check conductors run in multiple to insure that they are properly wired. Refer to installation instructions for complete unit installation details.

WARNING 

Before performing service or maintenance operations on system, turn off all main power switches. There may be more than one disconnect. Turn off accessory heater power switch if applicable. Electrical shock could cause serious injury or death.

TAG DISCONNECT SWITCH(ES) WITH A SUITABLE WARNING LABEL.

DUAL POINT DESCRIPTION

Use this instruction sheet for a scenario where a dual source circuit is required to power the electric heater and the unit contactor separately.

Installation:

1. Open all electrical disconnects before beginning any service work.
2. Insure that all unit duct work is installed per base unit installation instructions.
3. Remove access panel to heater compartment (See Fig. 1).
4. Check proper equipment model number from list.
5. Locate and remove heater access cover plate. Save screws.
6. Remove electric heater from the packaging.
7. Install heater, sliding assembly carefully through access hole. Ensure that mounting holes of heater align with mounting holes on the unit. Secure heater assemble with screws provided. Check operation as described in Start-Up section.
8. Remove electrical access panel (See Fig. 1) and inspect for sufficient clearance to punch a second power circuit above the existing high voltage knockout. Use a knock out punch to make a 7/8-in hole.
9. Attach Warning Label and electric heater dual point connection installer label to equipment (See Fig. 1).
10. Mark the unit name plate with an "X" next to the accessory heater "none". Refer to data plates for wire and maximum over current protection sizing.
11. Remove power line connection from heater to unit contactor and compressor. Refer to wire diagram for location of wires (See Fig.2 and Fig. 3).
12. Dress wires with wire ties provided.

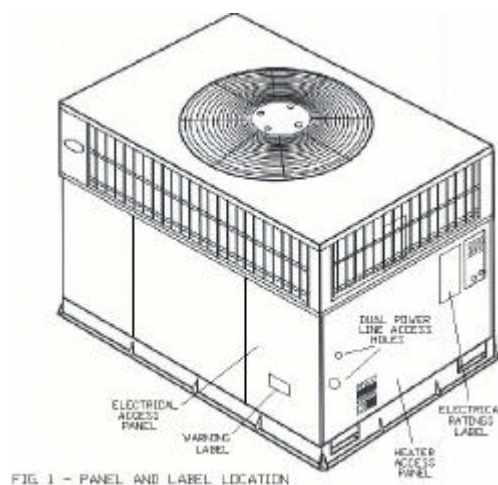

FIG 1 - PANEL AND LABEL LOCATION

Manufacturer reserves the right to discontinue, or change at any time, specifications or designs without notice and without incurring obligations.

WARNING

Before performing service or maintenance operations on system, turn off all main power switches.
There may be more than one disconnect. Turn off accessory heater power switch if applicable.
Electrical shock could cause serious injury or death.

TAG DISCONNECT SWITCH(ES) WITH A SUITABLE WARNING LABEL.

ELECTRICAL CONNECTIONS

1. Open all electrical disconnects before beginning any service work.
2. All electrical connections, wire sizes and type of conduit sizes shall meet the National Electric Code, State and Local Codes. Main power supply, minimum wire sizes, circuits, fusing, etc., is shown on schematic wiring diagrams.
NOTE: Use minimum 75°C copper wire only.
3. Refer to base unit instructions for recommended wiring procedures.
4. Insert field power line through the electrical heater access panel bottom hole and connect to the electric heater as shown on the wiring diagram. For fused models connect to the fuse block lugs and for non-fused models use wire nuts provided. Ground electrical equipment in the appropriate locations.
5. Insert second field power line through the electrical heater access panel top hole (See Fig. 1) and connect to unit contactor black and yellow leads using the wire nuts.
6. Connect low voltage wires as shown in heater schematic diagram (See Pg. 4). The connections must be made in the 24V barrier section inside unit panel (See Fig. 2). For 50CE,CR,DT,DU,XL,XT,604C,607B/D,707B/D connect the adaptor harness kit (provided with heater) to the low voltage wires of heater. Connect the harness plug to the mating 5 pin connector on the unit control board found at the bottom of the control box.
7. **Connect field power wiring as shown in heater wiring diagram. All connections should be made inside the air conditioning unit and comply with National Electric Codes, States and Local Codes. Heaters with factory installed fuses may be installed on a branch circuit protected by either a fuse or a circuit breaker. For all other heaters, the branch circuit must be protected by a fuse or circuit breaker supplied by others.**
8. Make all high voltage wire splice connections inside unit control box. Use splice connectors provided. Properly insulate connectors. Separate all wires from incoming power leads.
9. Check wiring diagram supplied with heater for specific connections and information.
10. Check operation as described in Start-Up section.

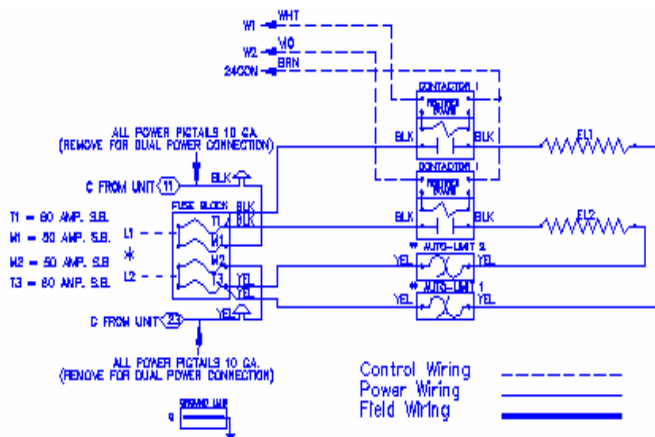

FIG. 2 - Wiring schematic for fused heater.

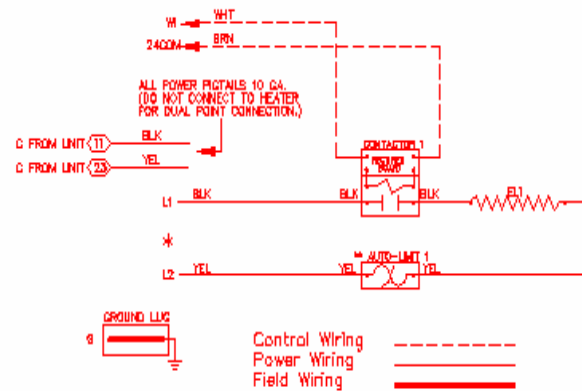

FIG. 3 - Wiring schematic for non-fused heater.

DUAL POINT KIT CONTENTS

1. Warning Label.
2. Heater electrical ratings label.
3. Installation Instructions.

Manufacturer reserves the right to discontinue, or change at any time, specifications or designs without notice and without incurring obligations.