

Electric Heater Model W6K series 208/240-60-1 208/240-60-3 480-60-3	INSTALLATION INSTRUCTIONS Date: 08/16/2016	York, Luxaire, Coleman, Champion, Fraser Johnston AHE / AHR / AHV / AP / AE / AVC / MP / ME / MVC / RFCX*E / RFCX*P Size 08-60 Air Handlers PHE / PCE - 24 - 60 Package Units
---	--	--

GENERAL

This electric heater series is engineered, designed, and approved to be installed in the (AHE / AHR / AHV / AP / AE / AVC / MP / ME / MVC / RFCX*E / RFCX*P Series) air handlers, and the PHE / PCE package units. Before proceeding, check the heater label for the correct voltage and KW requirements.

Installation and servicing of this equipment should only be performed by trained and qualified personnel. Before proceeding with the heater installation, inspect thoroughly for shipping damage. Notify the shipper immediately if any damage is found. Check all porcelain insulators for breakage and inspect heater element wire to see that none have been deformed. Clean all dirt, dust and moisture from equipment. **Check for proper clearances of live parts, between phases, and to ground.** Make sure that all required barriers are in place. Check conductors run in multiple to insure that they are properly wired. Refer to base installation instructions for complete unit installation details. **Verify that all elements are properly secure in their ceramic holders.**

WARNING

Before performing service or maintenance operations on system, turn off all main power switches. There may be more than one disconnect. Turn off accessory heater power switch if applicable. Electrical shock can cause personal injury. **TAG DISCONNECT SWITCH(ES) WITH A SUITABLE WARNING LABEL.** When installed in a garage, heater elements should have a clearance of 18" from the floor, insure that the area is ventilated.

HEATER INSTALLATION

1. Refer to the base unit installation instructions as required. Affix Warren Heater installer label to the equipment access panel.
2. Remove blower section access panel of the air handler unit.
3. Remove cover plate in front of blower assembly.
4. Slide heater assembly into blower section through the access opening (mounting position is important, check the label for correct position). Secure heater into place with screws from cover plate (see fig. 1).
5. Remove the conduit knockout in unit cabinet for electrical connections. Install the appropriate size conduit connector.
6. **480V models with single point transformer** - This part must be externally mounted and secured with screws onto the outside of the air handler unit (see fig. 3).
7. Apply the wiring diagram to the cabinet for future reference.

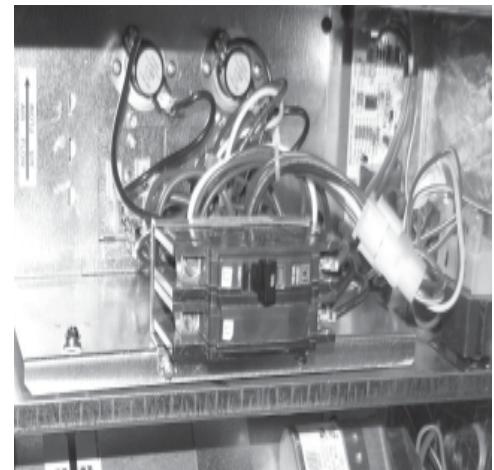

FIG. 1

HEATERS WITH CIRCUIT BREAKERS:

A BREAKER FILLER PLATE IS INCLUDED WITH ALL HEATER UNITS, PLEASE DO NOT DISCARD.

8. Remove circuit breaker knockout(s) in unit access panel as required and cut foil insulation from the breaker knockout area.
9. Install the breaker filler plate provided to protect breaker connections from contact with the foil faced insulation (see filler plate installation instructions).

NOTE: FOR HEATERS USING SQD TYPE BREAKERS A BREAKER FILLER PLATE MUST BE USED TO PROTECT THE BREAKER CONNECTIONS FROM CONTACT WITH THE FOIL INSULATION.

FILLER PLATE INSTALLATION INSTRUCTIONS (see fig. 2):

- A. Align breaker filler plate cut-out with the upper edge section of the breaker.
- B. Press the filler plate firmly around the upper edge of the breaker(s). Apply even pressure to all sides of the filler plate. Check that the filler plate is wrapped around the top edge of the breaker(s)

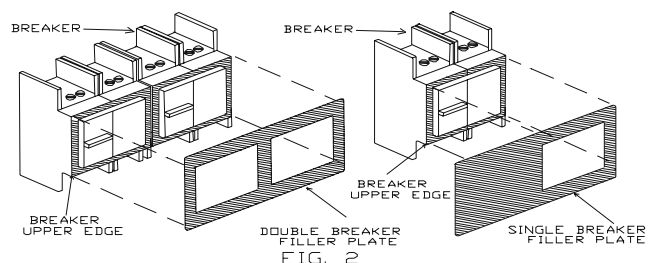

FIG. 2

Manufacturer reserves the right to discontinue, or change at any time, specifications or designs without notice and without incurring obligations.

N:\WORKSHEETS-NEW\W6K-INST081616

WARNING



Verify edges of foil faced insulation are not in contact with any exposed electrical connections.

ELECTRICAL CONNECTIONS

1. All electrical connections, wire sizes and type and conduit sizes shall meet the National Electric Code, State and Local Codes. Main power supply, minimum wire sizes, circuits, fusing, etc. is shown on schematic wiring diagrams.
NOTE: Use copper wire only.
2. Power may be brought into the unit through the top when unit is vertical position or the left side panel.
3. Refer to base unit instructions for recommended wiring procedures.
4. Remove the multi-pin connector with the jumper wire and discard. Connect the heater 6-pin socket connector to the corresponding plug in the air handler (see fig 1).
5. Separate all wires from incoming power leads.
6. **480V "A" model:** The transformer is for use on applications where 480V heaters are being wired into 208/240 volt single phase air handler units. The single point transformer must be externally mounted and secured with screws onto the air handler unit. Use the louvered transformer cover (provided) for protection of this part (see fig. 3). For wiring purposes the wiring on the transformer is labeled and color coded (refer to schematic), Use wire nuts to connect transformer leads to heater.
7. 480V "non transformer" model: Dual source circuit is required to power the electric heater and unit separately.
8. **Be sure that all electrical terminal connections, clamps, screws, etc. are tight before proceeding. Verify that there are no possible shorts to ground.**
9. Check wiring diagram supplied with heater for specific connections and information.
10. Check operation as described in start-up section.

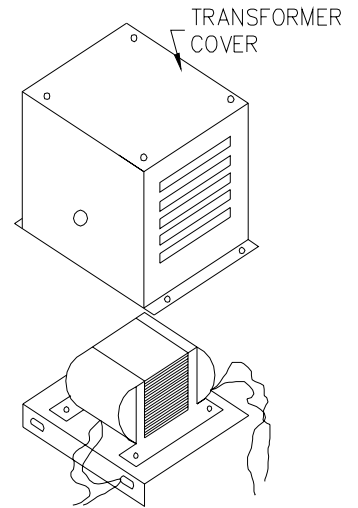

FIG. 3

START-UP AND CHECK-OUT

CAUTION: Before proceeding, verify that all wiring is correct per factory approved schematic. Notify factory immediately of any discrepancies.

1. Refer to base unit installation instructions as required.
2. **Check for loose terminal connections.**
3. Check that all fuse and circuit breaker short circuit interrupting ratings are adequate.
4. Turn on unit and heater power.
5. Set thermostat to call for heat.
6. Check operation of heater.
7. **Check that air flow across heater is at or above minimum recommended fan speed. Refer to base instructions for Air Flow Data Tables and adjustment of motor speed taps.**

CAUTION: When commissioning any AHU with electric heat, **ALWAYS** check to see if the heater is cycling on its automatic reset high temperature limit when the system is producing the highest temperature leaving the AHU coil. **If** the heater is cycling increase the air flow by increasing the fan speed or lowering the ductwork static pressure until cycling stops.

8. Any modification or repairs to this equipment without written permission from the factory will be done at the installer's own risk and expense.

HEATER KIT CONTENTS

1. Heater assembly
2. Installation Instructions
3. Installer label
4. Wiring diagram
5. Breaker filler plate (breaker models only)

USER CAUTION: The use of improperly selected air filters/ and or operation with dirty filters may result in insufficient airflow which may result in abnormal operation of electric heaters and tripping of temperature safety limits. Also, insufficient airflow will degrade the efficiency of the system (SEER rating) and excessive wear and premature failure of the system compressor may result. Other conditions, such as undersized or obstructed ductwork, may also cause insufficient airflow. It is recommended that a qualified technician be consulted to ensure proper airflow and air filtration selection and application. See (www.lowairflow.com) for more information.