

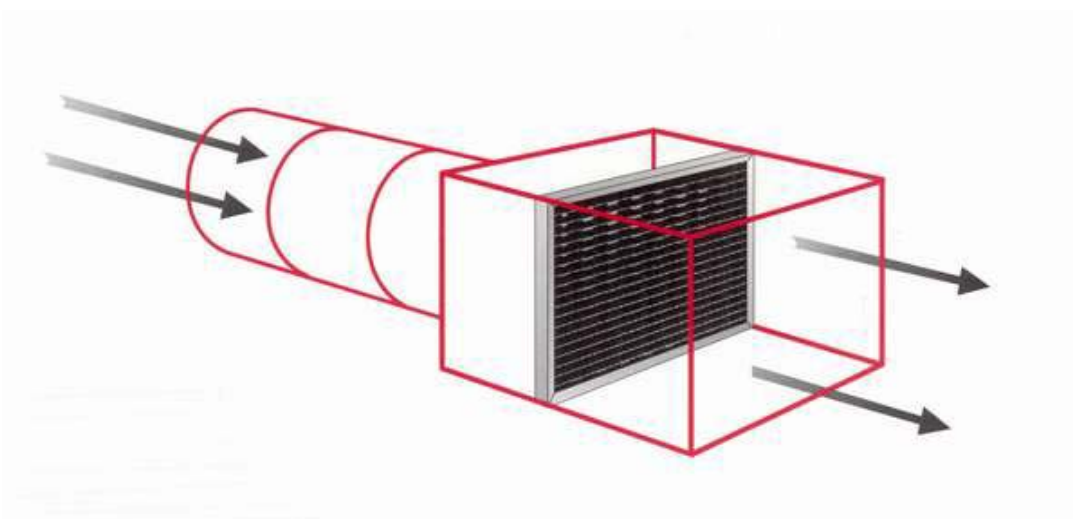

QUIET PLUS[®]

VARIABLE AIR VOLUME
TERMINAL UNITS



Featuring

Zebra[®]

Precision Air Valves

Model ST
Single Throttling

Catalog No. ST-00

TABLE OF CONTENTS
SINGLE DUCT THROTTLING UNIT

STATEMENT OF PURPOSE

As an established industry leader in the HVAC market, our philosophy is to add value to the industry by providing quality products and services, and to the community by encouraging participation in its development and progress.

We believe in the application of the Golden Rule to all our business relationships ... with our customers, management and employees, stockholders, sales representatives, suppliers, government, and the community; we believe we have definite obligations to each.

We also believe that our customers are entitled to products and services of the highest quality at a fair price. Our objective is to provide complete customer satisfaction. To assure that we meet this goal in our daily operations, management and employees subscribe to the following guidelines:

“Engineer, develop, manufacture and market quality products that meet or exceed industry standards.

Be a dependable source of supply and effect timely deliveries to meet customer needs.”

TABLE OF CONTENTS

Introduction	1
Air Flow Performance Data	2
Selection Procedure	3
Capacity and Dimensional Data	4
Performance Data	
Quick-Select Sound Data	5
Discharge Sound Power	6
Radiated Sound Power	7
Electric Heating Coils	8
Hot Water Heating Coils	10
Controls	13
Typical Control Configurations	14
Specifications/Applications	15
Recommended Design NC Levels	15
Installation Instructions	16
Metric Conversion Factors	16
Model Coding System	17

Due to a continuous process of product improvement, specifications &/or designs are subject to change at any time without notice and without incurring obligations.

®Quiet Plus and ®Zebra are registered trademarks of Warren Technology.

INTRODUCTION

SINGLE DUCT THROTTLING UNIT

Warren Quiet Plus® VAV Terminal Units

Variable Air Volume Terminal Units regulate the flow of conditioned supply-air into occupied spaces, to assure that comfortable temperature levels are maintained at much lower energy costs than other types of central systems.

Building owners and designers are aware and concerned about HVAC-system noise levels. Traditionally-designed VAV terminal units are often the most significant factor contributing to a noisy indoor environment. This has a significant impact on occupant comfort and productivity.

Advanced technology and experience have been combined by Warren to create a product line of VAV terminal units which offer a quantum improvement in VAV design and performance. Quiet Plus® VAV terminal units offer ultra-quiet operation plus laminar flow and precision control.

Warren Technology has invested extensively in engineering, product design, and testing in order to provide system designers with accurate flow and acoustic performance data.

Innovative, flexible manufacturing processes governed by modern computer-aided design and manufacturing (CAD/CAM) systems allow Warren to adapt quickly to new design requirements.

Model ST Single-Duct Throttling Units

The heart of the Quiet Plus® ST unit is the patented Zebra® precision air valve, which has the best performance for acoustics, laminar flow, and accurate control in the HVAC industry.

Model ST has 11 unit sizes, with capacities ranging from 100 to 5300 CFM. Electronic (analog or DDC), electric and pneumatic controls are available with velocity-sensing pressure-independent or thermostatically-driven pressure-dependent options. Control sequences can be chosen to meet virtually any cooling, heating, or ventilation requirement.

The Zebra®-damper's laminar-flow discharge profile offers unmatched performance when used with Warren's custom Electric or Hot-Water coils. Several insulation options are also available.

AIR FLOW PERFORMANCE DATA

SINGLE DUCT THROTTLING UNIT

CONTROLLABILITY

Warren Quiet Plus VAV Terminal Units have lower sound levels than conventional units. Oversizing to attain acceptable sound levels is unnecessary, so selection may be based on controllability, which ensures maximum performance.

Figure 2 shows the effect of airflow rate and ΔP_s on controllability for VAV valves. The maximum operating range of a VAV valve is the physical distance (linear or rotational) in which it modulates. The Effective Operating Range is equal to the maximum operating range minus the amount the valve must close to compensate for the system static pressure at the design airflow rate. Optimum controllability is attained by selecting the smallest sized unit which meets the design airflow and sound requirements.

Effective Operating Ranges of less than 50% are not recommended for VAV terminal units.

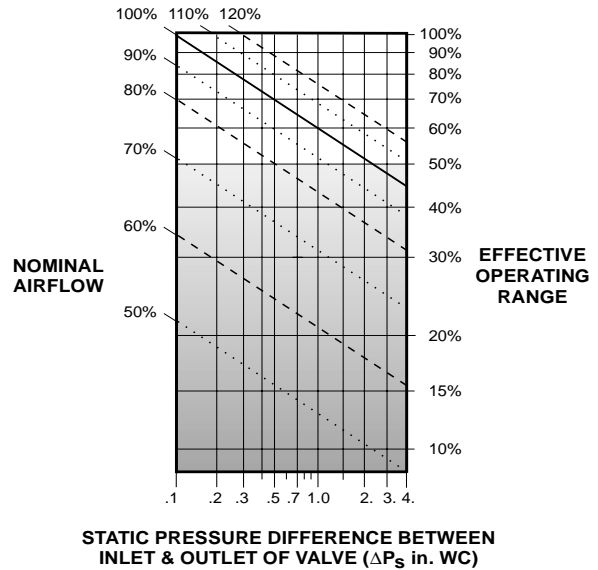

Figure 2. Controllability Graph

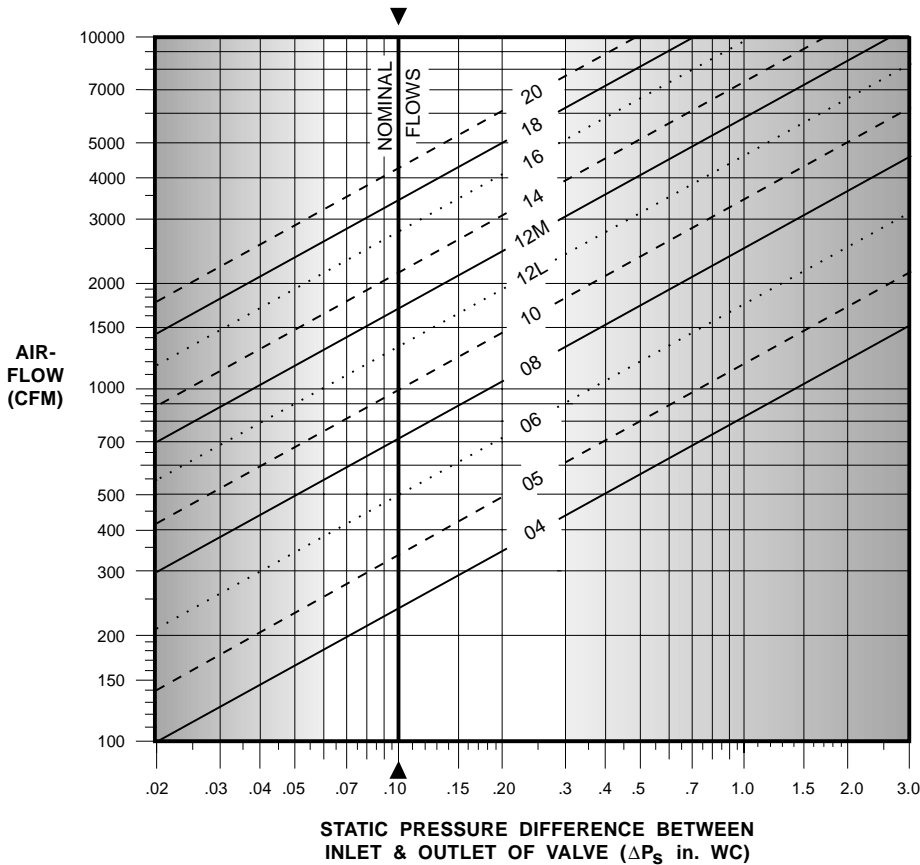

Figure 3. Warren Zebra Valve Airflow Performance Data

AIR FLOW CAPACITIES

Warren's Quiet Plus VAV Units are offered in a full range of terminal sizes to accommodate most specified airflow requirements.

Figure 3 shows airflow performance data (full open valve) for sizes 04-20 inches, given various static pressure differences between the inlet and outlet of the unit (ΔP_s).

Nominal capacities are based on a ΔP_s of 0.10 in. WC, 2000 FPM inlet velocity, 1000 FPM outlet velocity, and 100% effective operating range.

SELECTION PROCEDURE
SINGLE DUCT THROTTLING UNIT

SELECTION PROCESS

- A. Design data required:
1. Cooling CFM
 2. Inlet static pressure (ISP)
 3. External duct static pressure loss (ESP) downstream, not including coil
 4. Heating CFM (if required)
 5. Heating requirements in MBH or kW
 6. Maximum allowable NC or Sound Power
 7. Details about box installation and room, for acoustically-critical cases
- B. Establish the designation (see page 17 for other order-code details):
- STN = No heat
STE = Electric heat coil
STW = Hot water coil
- C. Select a unit size from Table 1 (page 4) for which the nominal cooling CFM most closely matches the design cooling CFM. *For optimum controllability, select nominal size or smaller. Oversizing will degrade the effective operating range of the unit.*
- D. If an electric heating coil is required, confirm that the design kW does not exceed the maximum allowable kW using Formula 6 (page 9). Use Tables 5–7 and the Procedure on pages 10–12 to select a hot water heating coil if required.
- E. Calculate the static pressure loss (ΔP_s) of the unit using the formula:
- $$\Delta P_s = \text{ISP} - (\text{ESP} + \text{HSP})$$
- Where:
- ΔP_s = static pressure loss of unit
ISP = inlet static pressure
ESP = external duct static pressure loss
HSP = static pressure loss of the heating coil as determined from Formula 7 (page 9) for electric coils or Table 7 (pages 11–12) for hot water coils.
- F. Confirm that the unit size selected does not exceed the maximum allowable NC by using Quick-Select Table 2 (page 5) for acoustically non-critical installations, or for critical installations use tables and formulae in Warren's *Acoustic Applications Guide*. If the unit selected exceeds the maximum allowable NC or Sound Power, then select the next larger unit size and repeat steps D and E.

- G. Check the effective operating range of the unit against the design requirements using Figure 2 (page 2). Calculate the percent of nominal airflow using the following formula:

$$\% \text{ of Nominal Airflow} = \frac{\text{Cooling CFM}}{\text{Nominal CFM}} \times 100$$

If the effective operating range of the unit selected falls below 50% on the graph, the next smaller unit should be considered. Re-select, and repeat steps D through F.

EXAMPLE (Typical Installation)

- A. Given design requirements:
1. Cooling CFM = 1700
 2. Inlet static pressure (ISP) = 1.30 in. WC
 3. External duct static pressure loss (ESP) = 0.26 in. WC
 4. Heating CFM = 850
 5. Heating coil = 8 kW
 6. Maximum allowable NC = 30
 7. Installation = not acoustically critical
- B. Since the design requires electric heat, the model designation is STE.
- C. From Table 1 (page 4) for 1700 CFM nominal, select size STE12M.
- D. Using Formula 6 (page 9), confirm that the required kW does not exceed the maximum allowable for the specified heating CFM. (850 Heating CFM \div 50 = 17.0 maximum allowable kW; therefore 8 kW at 850 CFM is acceptable.)
- E. Calculate the static pressure loss ΔP_s for the unit:
- $$\begin{aligned} \Delta P_s &= \text{ISP} - [\text{ESP} + \text{HSP}] \\ &= 1.30 - \left[0.26 + \left(0.08 \times \frac{850}{1700} \right) \right] \\ \Delta P_s &= 1.00 \text{ in. WC} \end{aligned}$$
- HSP was determined from Formula 7 (page 9).
- F. Quick-Select Table 2 (page 5) indicates that the NC of the selected unit does not exceed the maximum allowable NC 30. For size STE12M at 1700 CFM with 1.0" ΔP_s , both the discharge NC and the radiated NC are less than 20.
- G. The % of nominal airflow = 1700 \div 1700 = 100%. Checking the effective operating range at 100% for 1.0" ΔP_s from Figure 2 (page 2), it is determined that the effective operating range of the unit is 60% (effective operating ranges below 50% are not recommended).
The design requirements can be met with the selection of size STE12M.

CAPACITY AND DIMENSIONAL DATA
SINGLE DUCT THROTTLING UNIT

Table 1. Model ST Capacity and Dimensional Data

Model Number	Size (in.)	Inlet Shape ^⑦ (H x W)	Nominal CFM	Maximum CFM (Range)	Dimensions			Outlet		Weight (Est.) ^⑥ (lbs.)
					W (in.)	H (in.)	L ^⑤ (in.)	Width (in.)	Height (in.)	
ST_04L	4	Rnd	200	100-300	8	10	15	8	10	25
ST_05L	5	Rnd	300	150-400	8	10	15	8	10	25
ST_06L	6	Rnd	500	250-700	10	10	15	10	10	26
ST_08L	8	Rnd	700	350-900	14	10	15	14	10	28
ST_10L	10	8 x 11 ¹ / ₈	1000	600-1300	18	10	15	18	10	32
ST_12L	12	8 x 14 ¹ / ₄	1400	800-1800	24	10	15	24	10	35
ST_12M	12	Rnd	1700	1000-2200	20	15	15	20	15	36
ST_14M	14	Rnd	2100	1400-2700	24	15	15	24	15	38
ST_16M	16	14 x 17 ¹ / ₈	2600	1700-3400	30	15	15	30	15	43
ST_18M	18	14 x 20 ¹ / ₄	3300	2200-4200	38	15	15	36	15	47
ST_20M	20	14 x 23 ⁷ / ₁₆	4200	3000-5300	48	15	15	48	15	55

NOTES:

- 1) ST units include lined plenum, inlet collar, S & D outlet connection, and air valve assembly.
- 2) Nominal CFM based on maximum 2000 FPM inlet velocity, 1000 FPM outlet velocity, and ΔP_s of 0.10 in. WC.
- 3) STN = No heat STE = Electric heat coil STW = Hot water coil.
- 4) See page 16 for metric conversion factors.
- ⑤ Special controls may increase the length (L).
- ⑥ Add 25% to weight for electric heat or 1-row hot water coil; add 50% to weight for 2-row hot water coil.
- ⑦ Oval-inlet dimensions shown will fit inside flex-duct with "Size" diameter.

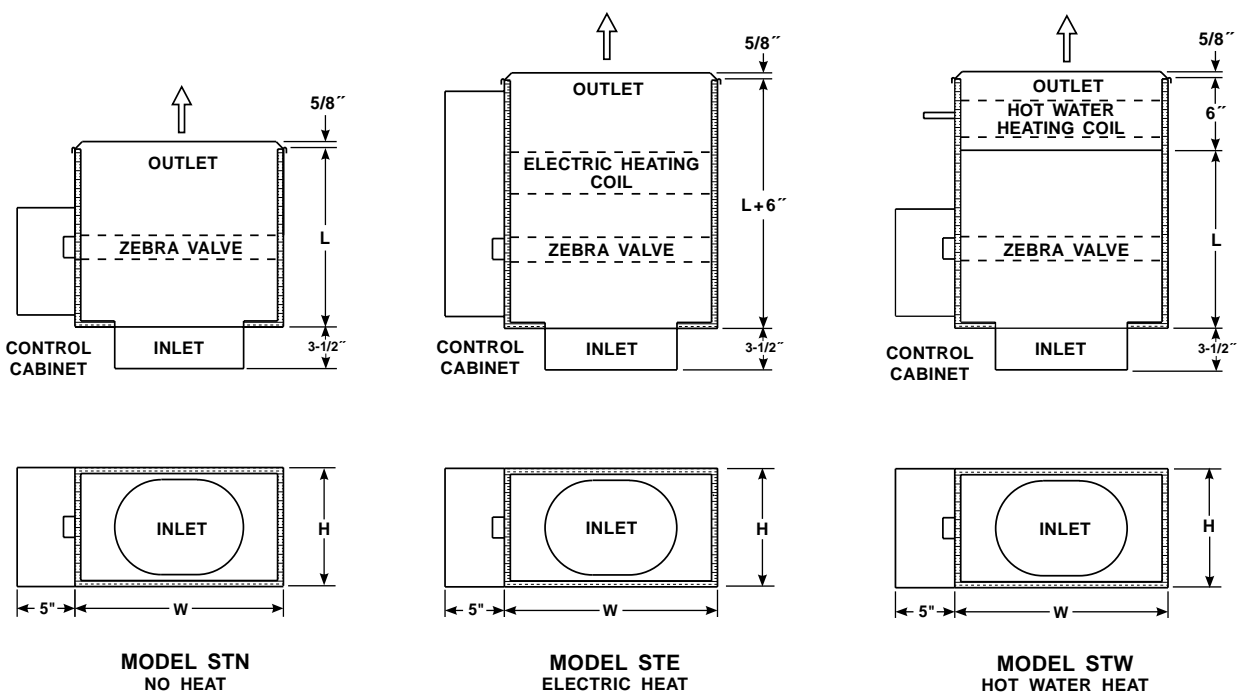

PERFORMANCE DATA
SINGLE DUCT THROTTLING UNIT

Table 2. Model ST QUICK-SELECT Sound Data, Discharge and Radiated NC Levels

Unit Size	CFM	Min ΔP_s	Min ΔP_s		0.5" ΔP_s		1.0" ΔP_s		3.0" ΔP_s	
			Dis	Rad	Dis	Rad	Dis	Rad	Dis	Rad
04L	150	.04	-	-	-	-	-	-	-	-
	200	.07	-	-	-	-	-	-	-	-
	250	.11	-	-	-	-	-	-	-	-
05L	200	.04	-	-	-	-	-	-	-	-
	300	.08	-	-	-	-	-	-	-	-
	400	.14	-	-	-	-	-	-	-	-
06L	400	.07	-	-	-	-	-	-	-	-
	500	.10	-	-	-	-	-	-	-	-
	600	.15	-	-	-	-	-	-	-	20
08L	500	.05	-	-	-	-	-	-	-	-
	700	.10	-	-	-	-	-	-	-	-
	900	.15	-	-	-	-	-	-	-	21
10L	800	.07	-	-	-	-	-	-	-	-
	1000	.10	-	-	-	-	-	-	-	-
	1200	.15	-	-	-	-	-	-	20	22
12L	1200	.08	-	-	-	-	-	-	-	-
	1400	.10	-	-	-	-	-	-	-	20
	1600	.15	-	-	-	-	-	-	-	23
12M	1300	.05	-	-	-	-	-	-	-	-
	1700	.10	-	-	-	-	-	-	-	22
	2000	.14	-	-	-	-	-	20	21	24
14M	1600	.06	-	-	-	-	-	-	-	-
	2100	.10	-	-	-	-	-	-	20	23
	2600	.15	-	20	-	21	-	22	24	26
16M	2000	.05	-	-	-	-	-	-	-	20
	2600	.08	-	-	-	-	-	-	21	24
	3200	.12	-	21	-	21	-	23	25	27
18M	2600	.06	-	-	-	-	-	-	24	22
	3300	.10	-	-	-	-	-	20	27	25
	4000	.13	-	23	-	23	-	24	28	29
20M	3400	.06	-	-	-	-	-	-	27	24
	4200	.10	-	-	-	20	22	22	30	27
	4800	.13	-	25	20	26	24	27	32	30

PERFORMANCE NOTES:

- 1) "-" indicates an NC level less than 20.
- 2) " ΔP_s " is the difference in static pressure from inlet to discharge, in. WC.
- 3) Test data obtained in accordance with ARI/ADC Test Standard 880.
- 4) Quick-Select NC levels are generated using tables and formulae in Warren's *Acoustic Applications Guide*.
- 5) Discharge NC levels are based on the following:
 - a) 10 dB room absorption
 - b) 5 feet of rectangular lined duct
 - c) 5 feet of standard flex duct
 - d) end reflection
 - e) flow division
- 6) Radiated NC levels are based on the following:
 - a) 10 dB room absorption
 - b) mineral fiber acoustical ceiling tile

PERFORMANCE DATA
SINGLE DUCT THROTTLING UNIT

Table 3. Model ST DISCHARGE Sound Power in Decibels

		Sound Power Levels, L _w , re 10 ⁻¹² Watts																												
Unit Size	CFM	Min ΔP _s	Min ΔP _s							0.5" ΔP _s							1.0" ΔP _s							3.0" ΔP _s						
			2	3	4	5	6	7	NC	2	3	4	5	6	7	NC	2	3	4	5	6	7	NC	2	3	4	5	6	7	NC
04L	150	.04	36	39	39	35	33	30	-	39	45	49	49	46	45	-	40	46	50	50	49	48	-	45	50	55	57	58	58	-
	200	.07	42	45	45	42	39	36	-	44	48	54	54	51	49	-	46	50	55	55	54	52	-	49	53	58	61	62	62	-
	250	.11	48	51	51	49	45	42	-	49	51	59	59	56	53	-	52	54	60	60	59	56	-	53	56	61	65	66	66	-
05L	200	.04	31	33	32	29	25	22	-	39	43	48	45	43	41	-	39	44	48	48	47	46	-	46	48	53	55	57	57	-
	300	.08	37	41	40	37	35	32	-	43	48	52	52	49	46	-	43	48	52	52	51	49	-	47	53	56	59	60	60	-
	400	.14	44	46	47	45	41	37	-	45	52	56	55	55	52	-	46	52	57	56	56	53	-	51	55	59	63	64	64	-
06L	400	.07	40	43	43	39	37	33	-	45	49	53	52	49	46	-	45	51	55	54	54	52	-	50	54	59	61	63	63	-
	500	.10	46	49	49	47	44	40	-	49	54	58	56	54	52	-	49	54	58	58	57	56	-	52	57	62	65	66	66	-
	600	.15	50	54	54	53	49	45	-	52	58	62	59	58	57	-	54	58	63	61	59	59	-	55	59	65	68	68	68	-
08L	500	.05	35	38	38	36	33	27	-	42	45	50	49	46	45	-	45	49	54	55	54	53	-	49	53	56	60	61	61	-
	700	.10	43	46	45	43	41	37	-	46	50	55	54	51	50	-	50	53	58	59	57	56	-	52	56	60	64	65	65	-
	900	.15	50	53	53	52	47	43	-	52	56	60	59	56	55	-	53	57	61	62	61	60	-	55	59	63	67	68	68	-
10L	800	.07	40	43	44	41	36	34	-	44	48	54	53	51	49	-	49	52	56	58	57	56	-	54	58	64	66	67	67	-
	1000	.10	45	48	50	47	43	40	-	48	53	57	56	54	53	-	52	55	60	61	60	58	-	56	60	65	68	69	69	-
	1200	.15	49	52	54	52	48	46	-	52	56	61	60	58	56	-	54	58	64	65	64	62	-	58	62	67	70	71	71	20
12L	1200	.08	38	41	43	39	36	35	-	45	49	55	54	51	50	-	49	53	59	59	58	57	-	56	59	65	68	67	67	-
	1400	.10	42	45	47	44	41	39	-	47	52	57	56	53	52	-	51	54	60	60	59	58	-	57	60	66	68	68	67	-
	1600	.15	46	48	51	48	45	43	-	49	54	59	58	55	54	-	52	56	61	62	61	60	-	59	62	67	69	69	68	-
12M	1300	.05	39	41	44	39	36	36	-	46	49	56	54	51	51	-	50	53	60	59	58	58	-	57	59	66	68	67	68	-
	1700	.10	47	48	52	48	45	44	-	50	54	60	58	55	55	-	53	56	62	62	61	61	-	60	62	68	69	69	69	-
	2000	.14	52	54	59	55	52	50	-	53	58	64	62	59	57	-	56	59	64	65	64	63	-	61	64	69	72	72	71	21
14M	1600	.06	38	41	45	43	39	37	-	49	53	57	56	55	54	-	51	54	59	61	60	60	-	57	60	66	68	69	69	-
	2100	.10	45	48	52	49	46	45	-	52	56	61	60	58	57	-	54	57	64	65	64	63	-	59	63	68	70	70	70	20
	2600	.15	52	55	58	56	53	51	-	55	59	64	63	61	59	-	57	61	68	68	66	65	-	62	65	70	74	74	74	24
16M	2000	.05	40	43	46	43	40	38	-	51	54	59	58	57	55	-	52	55	60	61	61	60	-	59	63	68	70	70	70	-
	2600	.08	47	50	53	50	47	45	-	54	58	63	62	60	59	-	55	58	64	65	64	63	-	61	65	70	73	73	73	21
	3200	.12	53	56	60	57	54	52	-	56	61	66	65	64	61	-	58	62	67	68	67	65	-	64	67	72	75	76	76	25
18M	2600	.06	42	46	49	47	43	41	-	52	56	61	60	59	57	-	55	58	63	65	64	64	-	60	64	69	72	72	72	24
	3300	.10	49	52	56	54	49	48	-	56	60	65	64	63	62	-	58	61	67	68	67	66	-	63	66	72	75	75	75	27
	4000	.13	56	59	63	60	57	55	-	59	63	68	67	65	63	-	62	65	69	71	69	68	-	66	69	75	77	78	78	28
20M	3400	.06	44	47	50	48	45	44	-	54	59	63	62	61	60	-	56	59	66	67	66	65	-	62	66	72	75	75	75	27
	4200	.10	52	55	58	56	52	49	-	58	63	66	65	64	63	-	60	64	69	70	69	68	22	65	69	74	77	77	77	30
	4800	.13	57	61	65	62	58	57	-	62	66	70	69	68	66	20	64	66	72	74	71	70	24	67	71	77	79	79	79	32

PERFORMANCE NOTES:

- 1) Test data obtained in accordance with ARI/ADC Test Standard 880.
- 2) Data is raw, without any corrections for room absorption, duct attenuation, multiple diffuser splits, etc.
- 3) Sound data listed is within ARI tolerances shown in the following table:

Band	2	3	4	5	6	7
Hz	125	250	500	1000	2000	4000
dB	6	4	3	3	3	3

- 4) "ΔP_s" is the difference in static pressure from inlet to discharge, in. WC.
- 5) "-" indicates an NC level less than 20.
- 6) Discharge NC levels are based on the following:
 - a) 10 dB room absorption
 - b) 5 feet of rectangular lined duct
 - c) 5 feet of standard flex duct
 - d) end reflection
 - e) flow division

PERFORMANCE DATA
SINGLE DUCT THROTTLING UNIT

Table 4. Model ST RADIATED Sound Power in Decibels

		Sound Power Levels, L _w , re 10 ⁻¹² Watts																												
Unit Size	CFM	Min ΔP _s	Min ΔP _s							0.5" ΔP _s							1.0" ΔP _s							3.0" ΔP _s						
			2	3	4	5	6	7	NC	2	3	4	5	6	7	NC	2	3	4	5	6	7	NC	2	3	4	5	6	7	NC
04L	150	.04	26	23	22	-	-	-	-	28	26	30	27	21	-	-	30	28	33	27	22	-	-	34	31	36	37	35	33	-
	200	.07	32	28	32	27	21	-	-	34	31	34	30	25	-	-	33	30	36	31	25	-	-	37	34	40	40	38	35	-
	250	.11	38	35	38	33	27	20	-	38	36	38	33	29	22	-	39	36	39	35	30	24	-	40	37	44	43	41	37	-
05L	200	.04	22	20	-	-	-	-	-	26	23	27	24	-	-	-	27	26	31	27	22	-	-	33	30	35	36	35	32	-
	300	.08	28	26	25	-	-	-	-	31	28	32	29	24	-	-	31	31	35	29	25	-	-	36	34	38	39	37	35	-
	400	.14	34	31	34	29	23	-	-	34	32	36	32	26	20	-	34	33	38	33	27	21	-	40	37	42	41	39	36	-
06L	400	.07	31	28	27	22	-	-	-	33	31	34	31	25	-	-	34	32	37	32	29	23	-	37	35	40	42	39	36	-
	500	.10	37	33	36	32	25	-	-	37	35	39	35	27	22	-	37	35	40	36	30	27	-	42	38	44	44	42	38	-
	600	.15	41	38	41	37	29	24	-	41	39	43	39	30	26	-	42	39	44	40	31	28	-	46	41	48	46	45	39	20
08L	500	.05	29	26	-	-	-	-	-	34	30	34	30	25	-	-	35	32	37	35	31	26	-	37	35	39	41	39	37	-
	700	.10	34	31	31	24	-	-	-	36	34	38	35	29	22	-	39	35	41	38	33	27	-	42	40	44	44	42	39	-
	900	.15	38	35	39	35	28	21	-	42	38	42	39	33	26	-	43	39	45	43	34	29	-	45	42	46	47	45	41	21
10L	800	.07	30	28	23	-	-	-	-	35	33	36	31	24	-	-	38	36	39	36	31	26	-	41	39	44	43	42	39	-
	1000	.10	37	36	35	27	-	-	-	39	37	39	35	27	21	-	42	39	42	39	34	29	-	44	43	46	45	43	41	-
	1200	.15	42	41	41	37	29	-	-	44	42	44	39	32	25	-	45	44	46	44	37	31	-	47	45	49	48	46	43	22
12L	1200	.08	36	32	31	-	-	-	-	36	35	37	29	22	-	-	38	36	40	37	33	28	-	44	42	46	44	42	40	-
	1400	.10	39	35	36	26	-	-	-	39	37	40	32	25	-	-	42	38	42	39	35	30	-	46	44	48	45	43	41	20
	1600	.15	42	39	40	33	22	-	-	42	39	42	35	27	21	-	45	40	44	40	36	31	-	47	45	51	47	45	43	23
12M	1300	.05	36	33	32	-	-	-	-	37	36	38	29	23	-	-	39	36	41	38	33	29	-	45	42	46	45	43	40	-
	1700	.10	43	40	41	33	23	-	-	43	40	43	36	27	22	-	46	41	44	41	36	32	-	48	45	50	48	46	43	22
	2000	.14	46	43	46	40	33	26	-	47	44	47	39	33	25	-	49	44	48	44	39	35	20	51	48	52	50	47	44	24
14M	1600	.06	37	34	30	-	-	-	-	36	35	37	31	24	-	-	40	38	41	39	34	28	-	44	43	46	45	43	41	-
	2100	.10	42	39	40	34	24	-	-	42	41	43	37	29	22	-	44	43	45	44	37	32	-	48	46	50	47	46	43	23
	2600	.15	47	46	48	44	37	27	20	47	46	49	45	37	27	21	47	46	49	47	41	34	22	51	49	53	50	48	45	26
16M	2000	.05	38	34	30	22	-	-	-	38	36	38	32	25	-	-	41	39	42	39	35	30	-	45	44	47	46	44	42	20
	2600	.08	43	41	40	36	26	-	-	44	42	44	39	30	23	-	45	43	47	44	39	33	-	49	47	52	49	46	44	24
	3200	.12	49	46	49	44	37	28	21	49	46	49	45	38	29	21	49	47	51	48	42	36	23	52	51	55	52	49	46	27
18M	2600	.06	39	36	33	26	-	-	-	41	38	40	34	27	-	-	44	41	45	43	37	32	-	46	46	49	48	46	44	22
	3300	.10	45	43	42	37	27	-	-	45	44	46	40	32	25	-	46	45	48	46	42	35	20	51	50	53	51	49	46	25
	4000	.13	51	48	51	46	38	30	23	51	48	51	47	39	30	23	52	49	52	49	45	37	24	55	53	56	54	51	49	29
20M	3400	.06	42	38	35	27	-	-	-	42	41	42	36	29	22	-	45	43	46	45	38	34	-	49	48	51	50	48	46	24
	4200	.10	47	45	45	39	29	-	-	47	46	48	43	35	26	20	49	47	50	48	43	37	22	53	52	55	53	51	48	27
	4800	.13	53	51	53	47	40	33	25	53	51	54	49	40	33	26	53	51	55	52	46	39	27	56	55	58	56	53	50	30

PERFORMANCE NOTES:

- 1) Test data obtained in accordance with ARI/ADC Test Standard 880.
- 2) Data is raw, without any corrections for room absorption, or ceiling effect.
- 3) Sound data listed is within ARI tolerances shown in the following table:

Band	2	3	4	5	6	7
Hz	125	250	500	1000	2000	4000
dB	6	4	3	3	3	3

- 4) "ΔP_s" is the difference in static pressure from inlet to discharge, in. WC.
- 5) "-" indicates an NC level less than 20.
- 6) Radiated NC levels are based on the following:
 - a) 10 dB room absorption
 - b) mineral fiber acoustical ceiling tile

ELECTRIC HEATING COILS SINGLE DUCT THROTTLING UNIT

Standard Heater Features for Terminal Units

with Electric Controls:

- Automatic Reset Thermal Cutout
- Backup Thermal Cutout
- De-energizing Magnetic Contactors
- Transformer for 24 Volt Controls
- Power Terminal Block

Standard Heater Features for Terminal Units

with Pneumatic Controls:

- Automatic Reset Thermal Cutout
- Backup Thermal Cutout
- Pneumatic Electric Switches
- Power Terminal Block

Optional Features:

- Air Flow Switches
- Disconnect Switch
- Magnetic Disconnecting Contactors
- Mercury De-energizing Contactors
- Mercury Disconnecting Contactors
- Fusing
- SCR Controls

DESCRIPTION

As an industry leader in open-coil electric heating technology, Warren now offers that same technology in heaters designed for VAV applications. Warren heaters provide maximum versatility and dependability. Elements are computer selected using the "Calculated Wire Temperature Method" to ensure that exact electrical and heat characteristics are achieved. Coupled with the laminar air flow of the patented Zebra® precision damper, Quiet Plus® VAV units assure optimum heater element performance, even at minimum airflow settings. A broad range of control options and accessories is available, allowing customization of VAV heat operation.

UNIQUE ELEMENT DESIGN

Warren's design criteria for heating element selection is based on actual element operating temperature.

Warren selects all elements using its exclusive "Calculated Wire Temperature Method". This method ensures that the elements operate with-

in the designed electrical and temperature requirements, and do not exceed the melting point of the alloy, even in still, free air.

This method allows Warren to determine the exact operating temperature of the heater elements. The elements are designed to operate below the maximum allowable temperature recommended by the element alloy manufacturer. This process eliminates most problems associated with hot spots in heaters caused by poor air distribution.

This method of design has resulted in a near zero failure rate for units properly installed in the field over the past two decades.

COMPUTERIZED SELECTION

Our computer selection program, developed after years of research, ensures that Warren heaters can meet an infinite number of size and voltage requirements. Exact performance and life expectancy of the element can be determined under specific conditions.

ELECTRIC HEATING COILS SINGLE DUCT THROTTLING UNIT

ELEMENT SUPPORT SYSTEM

Warren utilizes a patented element support system that permits the ceramic insulators to expand and contract freely without cracking or breaking. Ceramic insulators are made of high grade refractory materials.

CONSTRUCTION

Warren employs the most modern technology available in the industry to construct the heater frames and boxes. All heaters are produced from standard components incorporated in an exclusive modular design. All frames and boxes are constructed of heavy gauge, galvanized steel. The frame is integrally mounted to the control box, providing solid one-piece construction for ease of installation.

SELECTION & DESIGN

Quiet Plus® electric heaters are custom-designed for each terminal unit's specific combination of airflow, heating capacity, entering air temperature, free area velocity, max operating temperature (or de-rating factor), number of control steps, air density, and electrical characteristics. The selection process is simplified, since only the max heating capacity must be checked. The air-side pressure drop is a function of all the factors above, and is so low for all applications that only a rough approximation is required for application-design purposes. Therefore, a few simple formulae suffice for coil selection.

PERMANENT ELECTRONIC FILE

A permanent electronic file for each control panel is made and retained for future reference. Having this record on file allows Warren to produce identical heaters at a later date, offer precise engineering assistance to the installing contractor and service personnel, and supply replacement parts identical to those originally furnished. This feature is offered exclusively by Warren.

ENGINEERING DATA

General:

1. Conversion: 1 kW = 3413 BTU/hr
2. Load Req: kW = CFM x $\Delta^{\circ}\text{F}$ / 3160
3. Watts = Volts x Amps = Volts² / Ohms
4. 1-phase Amps = Watts / Volts
5. 3-phase Amps = Watts / (Volts x 1.73)

Coil-Specific:

6. Max Allowed kW = Htg CFM / 50
7. Air ΔP in. WC = 0.08 x Htg CFM / Clg CFM

EXAMPLE

Heating CFM = 850, Cooling CFM = 1700,
Temp Rise = 25°F, Volts/phase = 240V/3ph
Load: 850 CFM x 25°F / 3160 = 6.7 kW
Current: 6700 W / (240 V x 1.73) = 16.1 A
Max kW Allowed: 850 CFM / 50 = 17.0 kW
Pressure Loss: 0.08 x 850 / 1700 = 0.04 in. WC

SAMPLE SPECIFICATION

- Electric Duct Heaters shall be open coil type as manufactured by Warren Technology. Voltage, kW, size, number of steps, and accessories shall be as shown. Units shall be UL listed for zero clearance and meet all applicable requirements of the latest National Electric Code and ANSI standards.
- Heating elements shall be high grade nickel-chrome. Element temperatures shall not exceed 400°F below the melting point of the element alloy when energized with design voltage in still, free air at 75°F.
- Heater frames and control boxes shall be constructed of 20 gauge galvanized steel or heavier. Frames shall be hot dipped galvanized after fabrication if spot welds are used.
- Mounting assemblies for the element support insulators shall pass between the insulators permitting free expansion of the insulators under high temperature conditions without cracking or breaking.
- Each heater shall have its load divided into equal steps as shown. All necessary controls for recycling shall be provided in heaters of more than 48 amps.

HOT WATER HEATING COILS SINGLE DUCT THROTTLING UNIT

Standard Features:

- Galvanized Casing
- Slip & Drive Connections
- Aluminum Finned Tubular Construction
- All Copper Tubes
- 1/2" O.D. Male Connections

SELECTION PROCEDURE FOR HOT WATER COILS:

1. Use the cooling CFM, max allowed SP drop, and max noise level to select a unit size from Tables 2–4 (pgs. 5–7). Check Figure 2 (pg. 2) to assure the selection will have an acceptable effective operating range (should be above 50% of full-travel).
2. Check the heating-coil data in Table 7 for that unit's size. If the design CFM is within the table's range, check if adequate heating capacity (MBH) &/or airside ΔT is available for the application (use corrections from Tables 5–6 below if necessary). Select one-row coils if possible, to reduce SP penalties and cost. If the required CFM or heating capacity is outside the table's range, consider using a different water temperature, or a different unit size.

Table 5. MBH and ΔT Correction Factors for Entering Water – Air Temp other than 130°F

Correction Factor = (Entering Water Temp – Entering Air Temp) / 130°F

Ent'g H₂O-Air °F	70	80	90	100	110	120	130	140	150	160
Correction Factor	0.54	0.62	0.69	0.77	0.85	0.92	1.00	1.08	1.15	1.23

Table 6. CFM Correction Factors for Air Density other than Sea Level at 55°F

Correction Factor = 0.0564 x (460 + Deg. F) / [29.9 – (0.000956 x Feet)]

Elevation (feet)		-1000	0	1000	2000	3000	4000	5000	6000	7000	8000
CFM	70°F	0.97	1.00	1.03	1.07	1.11	1.15	1.19	1.24	1.29	1.34
Factor	55°F	0.94	0.97	1.00	1.04	1.07	1.11	1.16	1.20	1.25	1.31

Notes for Hot-Water Coil Selection Table 7:

1. Tables are based on a 130°F temperature difference between entering water (185°F) and entering air (55°F). CFM values are based on air density entering the coil at Sea Level and 55°F. For other entering water-air temperature differences, multiply the rated MBH and air ΔT by a factor from Table 5. For other entering-air conditions, multiply the rated CFM by a factor from Table 6. *The coil may be active during the day while system is in cooling mode, if non-zero minimum flow-rates are used, or if the zone needs heating. During early-morning warmup cycles when the AHU is recirculating return air, the hot-water coil's entering air will gradually increase from night-setback temperature to daytime room temperature. The airside ΔT across the coil will decrease as the air temperature entering the coil gets closer to the supply water temperature. Typical HW supply temp's are 170–200°F.*
2. The fins per inch, water circuits and water velocity in each coil have been carefully selected to optimize the unit's performance and general applicability in its CFM range. The highest one-row coil capacity typically overlaps the lowest capacity for the same unit's two-row coil at the same airflow rate. If performance outside the specified CFM or MBH ranges is required, contact the factory for customized selections. *Tables are based on one-row coils with 14 fins/inch and two-row coils with 8 fins/inch. Fins are typically .0055" thick corrugated aluminum on 0.016" thick half-inch copper tubes. Number of circuits ranges from 1 to 6, depending on the application. Header connection pipe sizes vary with number of circuits. These details may vary by application.*
3. Water flow rate (GPM) and head loss (feet of water) columns are based on 1.0, 3.0, 5.0, and 7.0 FPS water-velocity through the coils. GPM varies from one coil to another for a given FPS based on the number of circuits. Head-loss varies based on the total tube-length of the coil and header. If performance outside the specified GPM or ft. H₂O ranges is required, contact the factory for customized selections. *Selections at water velocities higher than 7 FPS result in significant head-loss increases, with minor increases in capacity. Water velocity selections lower than 1 FPS are in the laminar-flow region, which results in major changes in capacity with minor changes in velocity, making the coil harder to control in a stable fashion.*

HOT WATER HEATING COILS SINGLE DUCT THROTTLING UNIT

Table 7. Hot Water Heating Coil Data

SIZE		AR SIDE		WATERSIDE				
04L	1 row 1/2" O.D.	Heating CFM	SP loss in. H ₂ O	Ft. H ₂ O:	0.13	0.85	2.05	3.67
				GPM:	0.60	1.80	2.90	4.10
10" h 8" w	1 row 1/2" O.D.	50	0.00	MBH:	4.2	4.6	4.7	4.8
				Air ΔT:	76	83	85	86
				MBH:	7.3	8.8	9.2	9.4
		150	0.03	Air ΔT:	44	53	56	57
				MBH:	8.8	11.1	11.8	12.2
				Air ΔT:	32	41	43	44
	2 row 1/2" O.D.	50	0.01	Ft. H ₂ O:	0.27	1.75	4.23	7.59
				GPM:	0.60	1.80	2.90	4.10
				MBH:	5.2	5.6	5.7	5.7
		150	0.04	Air ΔT:	94	101	103	104
				MBH:	9.6	11.3	11.7	11.9
				Air ΔT:	58	68	71	72
250	0.10	MBH:	11.9	14.6	15.4	15.7		
		Air ΔT:	43	53	56	57		

SIZE		AR SIDE		WATERSIDE				
05L	1 row 1/2" O.D.	Heating CFM	SP loss in. H ₂ O	Ft. H ₂ O:	0.13	0.85	2.05	3.67
				GPM:	0.60	1.80	2.90	4.10
10" h 8" w	1 row 1/2" O.D.	80	0.01	MBH:	5.5	6.3	6.5	6.6
				Air ΔT:	62	71	73	74
				MBH:	8.7	10.9	11.6	11.9
		240	0.07	Air ΔT:	33	41	44	45
				MBH:	10.1	13.4	14.5	15.0
				Air ΔT:	23	30	33	34
	2 row 1/2" O.D.	80	0.01	Ft. H ₂ O:	0.27	1.75	4.23	7.59
				GPM:	0.60	1.80	2.90	4.10
				MBH:	7.0	7.8	8.0	8.1
		240	0.10	Air ΔT:	79	88	90	91
				MBH:	11.7	14.3	15.1	15.4
				Air ΔT:	44	54	57	58
400	0.24	MBH:	14.0	18.0	19.1	19.7		
		Air ΔT:	32	41	43	45		

SIZE		AR SIDE		WATERSIDE				
06L	1 row 1/2" O.D.	Heating CFM	SP loss in. H ₂ O	Ft. H ₂ O:	0.15	0.96	2.32	4.16
				GPM:	0.60	1.80	2.90	4.10
10" h 10" w	1 row 1/2" O.D.	120	0.01	MBH:	7.3	8.6	9.0	9.1
				Air ΔT:	55	65	67	69
				MBH:	11.1	14.5	15.6	16.1
		360	0.10	Air ΔT:	28	36	39	40
				MBH:	12.7	17.6	19.2	20.0
				Air ΔT:	19	26	29	30
	2 row 1/2" O.D.	120	0.02	Ft. H ₂ O:	0.30	1.97	4.77	8.56
				GPM:	0.60	1.80	2.90	4.10
				MBH:	9.4	10.8	11.1	11.3
		360	0.13	Air ΔT:	71	81	84	85
				MBH:	14.9	19.1	20.3	20.9
				Air ΔT:	37	48	51	52
600	0.33	MBH:	17.4	23.6	25.5	26.4		
		Air ΔT:	26	36	38	40		

SIZE		AR SIDE		WATERSIDE				
08L	1 row 5/8" O.D.	Heating CFM	SP loss in. H ₂ O	Ft. H ₂ O:	0.09	0.56	1.36	2.44
				GPM:	1.20	3.50	5.80	8.10
10" h 14" w	1 row 5/8" O.D.	180	0.02	MBH:	11.0	12.7	13.2	13.4
				Air ΔT:	55	64	66	67
				MBH:	16.8	21.4	22.8	23.5
		540	0.11	Air ΔT:	28	36	38	39
				MBH:	19.5	26.0	28.2	29.3
				Air ΔT:	20	26	28	29
	2 row 5/8" O.D.	180	0.02	Ft. H ₂ O:	0.18	1.18	2.86	5.13
				GPM:	1.20	3.50	5.80	8.10
				MBH:	14.2	16.0	16.5	16.7
		540	0.15	Air ΔT:	71	80	83	84
				MBH:	23.0	28.4	30.0	30.7
				Air ΔT:	39	48	50	51
900	0.37	MBH:	27.2	35.2	37.6	38.8		
		Air ΔT:	27	35	38	39		

SIZE		AR SIDE		WATERSIDE				
10L	1 row 5/8" O.D.	Heating CFM	SP loss in. H ₂ O	Ft. H ₂ O:	0.10	0.67	1.63	2.92
				GPM:	1.20	3.50	5.80	8.10
10" h 18" w	1 row 5/8" O.D.	240	0.02	MBH:	14.0	16.5	17.2	17.5
				Air ΔT:	53	62	65	66
				MBH:	21.0	27.5	29.5	30.5
		720	0.12	Air ΔT:	26	34	37	38
				MBH:	24.1	33.2	36.2	37.8
				Air ΔT:	18	25	27	28
	2 row 5/8" O.D.	240	0.02	Ft. H ₂ O:	0.22	1.40	3.40	6.10
				GPM:	1.20	3.50	5.80	8.10
				MBH:	18.1	20.8	21.5	21.8
		720	0.16	Air ΔT:	68	78	81	82
				MBH:	28.5	36.4	38.7	39.8
				Air ΔT:	36	46	49	50
1200	0.40	MBH:	33.2	44.8	48.3	50.0		
		Air ΔT:	25	34	36	38		

**Ratings for Models 12L, 12M,
14M, 16M, 18M, & 20M
continued on the next page...**

HOT WATER HEATING COILS SINGLE DUCT THROTTLING UNIT

Table 7 (cont'd). Hot Water Heating Coil Data

SIZE		AR SIDE		WATERSIDE				
12L	10" h 24" w	Heating CFM	SP loss in. H ₂ O	Ft. H ₂ O:	0.13	0.84	2.04	3.65
				GPM:	1.20	3.50	5.80	8.10
5/8" O.D.	1 row	320	0.02	MBH:	17.9	21.7	22.7	23.2
				Air ΔT:	51	61	64	65
		960	0.12	MBH:	26.3	35.7	38.7	40.2
	1600	0.30	MBH:	29.9	42.9	47.3	49.6	
			Air ΔT:	17	24	27	28	
			2 row	Heating CFM	SP loss in. H ₂ O	Ft. H ₂ O:	0.27	1.74
5/8" O.D.	2 row	320	0.02	GPM:	1.20	3.50	5.80	8.10
				MBH:	23.0	27.3	28.4	28.9
		960	0.16	Air ΔT:	65	77	80	81
	1600	0.40	MBH:	35.2	47.1	50.6	52.3	
			Air ΔT:	33	44	48	49	
			MBH:	40.4	57.4	62.9	65.5	
Air ΔT:	23	32	35	37				

SIZE		AR SIDE		WATERSIDE				
12M	15" h 20" w	Heating CFM	SP loss in. H ₂ O	Ft. H ₂ O:	0.17	1.12	2.72	4.87
				GPM:	1.20	3.50	5.80	8.10
5/8" O.D.	1 row	400	0.02	MBH:	21.6	26.7	28.1	28.8
				Air ΔT:	49	60	63	65
		1200	0.12	MBH:	31.0	43.5	47.6	49.7
	2000	0.30	MBH:	23	33	36	37	
			Air ΔT:	16	23	26	28	
			2 row	Heating CFM	SP loss in. H ₂ O	Ft. H ₂ O:	0.21	1.49
7/8" O.D.	2 row	400	0.02	GPM:	1.70	5.20	8.70	12.20
				MBH:	29.3	34.5	35.7	36.3
		1200	0.16	Air ΔT:	66	78	81	82
	2000	0.40	MBH:	45.4	60.0	64.1	66.0	
			Air ΔT:	34	45	48	50	
			MBH:	52.4	73.5	79.8	82.9	
Air ΔT:	24	33	36	37				

SIZE		AR SIDE		WATERSIDE				
14M	15" h 24" w	Heating CFM	SP loss in. H ₂ O	Ft. H ₂ O:	0.12	0.83	2.04	3.68
				GPM:	1.70	5.20	8.70	12.20
7/8" O.D.	1 row	520	0.02	MBH:	27.4	33.9	35.6	36.4
				Air ΔT:	48	59	62	63
		1560	0.14	MBH:	39.4	55.1	60.0	62.5
	2600	0.35	MBH:	23	32	35	36	
			Air ΔT:	15	23	25	26	
			2 row	Heating CFM	SP loss in. H ₂ O	Ft. H ₂ O:	0.24	1.71
7/8" O.D.	2 row	520	0.03	GPM:	1.70	5.20	8.70	12.20
				MBH:	35.4	42.8	44.7	45.5
		1560	0.19	Air ΔT:	61	74	78	79
	2600	0.46	MBH:	52.9	72.9	78.7	81.5	
			Air ΔT:	31	42	46	47	
			MBH:	60.2	88.5	97.3	101.7	
Air ΔT:	21	31	34	35				

SIZE		AR SIDE		WATERSIDE				
16M	15" h 30" w	Heating CFM	SP loss in. H ₂ O	Ft. H ₂ O:	0.14	0.99	2.44	4.41
				GPM:	1.70	5.20	8.70	12.20
7/8" O.D.	1 row	640	0.02	MBH:	32.7	41.3	43.7	44.8
				Air ΔT:	46	58	62	63
		1920	0.14	MBH:	46.1	66.7	73.3	76.6
	3200	0.34	MBH:	22	31	35	36	
			Air ΔT:	15	22	25	27	
			2 row	Heating CFM	SP loss in. H ₂ O	Ft. H ₂ O:	0.15	0.99
9/8" O.D.	2 row	640	0.03	GPM:	3.50	10.40	17.30	24.20
				MBH:	47.6	54.5	56.2	57.0
		1920	0.18	Air ΔT:	67	77	79	80
	3200	0.45	MBH:	75.1	94.9	100.6	103.3	
			Air ΔT:	35	45	47	49	
			MBH:	87.7	116.7	125.4	129.7	
Air ΔT:	25	33	35	37				

SIZE		AR SIDE		WATERSIDE				
18M	15" h 38" w	Heating CFM	SP loss in. H ₂ O	Ft. H ₂ O:	0.17	1.21	2.98	5.39
				GPM:	1.70	5.20	8.70	12.20
7/8" O.D.	1 row	800	0.02	MBH:	39.0	50.9	54.2	55.8
				Air ΔT:	44	57	61	63
		2400	0.13	MBH:	53.6	81.3	90.4	95.0
	4000	0.33	MBH:	20	31	34	36	
			Air ΔT:	13	22	25	26	
			2 row	Heating CFM	SP loss in. H ₂ O	Ft. H ₂ O:	0.18	1.21
9/8" O.D.	2 row	800	0.03	GPM:	3.50	10.40	17.30	24.20
				MBH:	58.0	67.7	70.1	71.3
		2400	0.18	Air ΔT:	65	76	79	80
	4000	0.44	MBH:	89.7	117.1	124.9	128.7	
			Air ΔT:	34	44	47	48	
			MBH:	103.8	143.3	155.4	161.4	
Air ΔT:	23	32	35	36				

SIZE		AR SIDE		WATERSIDE				
20M	15" h 48" w	Heating CFM	SP loss in. H ₂ O	Ft. H ₂ O:	0.21	1.49	3.66	6.61
				GPM:	1.70	5.20	8.70	12.20
7/8" O.D.	1 row	960	0.02	MBH:	45.3	61.1	65.6	67.7
				Air ΔT:	43	58	62	64
		2880	0.12	MBH:	60.8	96.7	108.9	115.1
	4800	0.30	MBH:	19	30	34	36	
			Air ΔT:	13	21	25	26	
			2 row	Heating CFM	SP loss in. H ₂ O	Ft. H ₂ O:	0.22	1.49
9/8" O.D.	2 row	960	0.02	GPM:	3.50	10.40	17.30	24.20
				MBH:	68.7	81.8	85.1	86.6
		2880	0.16	Air ΔT:	65	77	80	81
	4800	0.40	MBH:	104.5	141.0	151.7	156.9	
			Air ΔT:	33	44	48	49	
			MBH:	119.8	172.0	188.4	196.6	
Air ΔT:	23	32	35	37				

WARREN QUIET PLUS VAV TERMINAL UNITS

CONTROLS

SINGLE DUCT THROTTLING UNIT

BASIC CONTROL MODES

1. Full-Range Pressure Independent with Max and Min Flow Settings

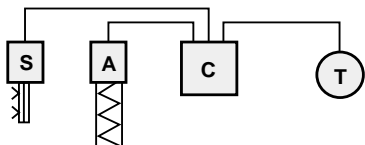

The air flow is sensed by the controller (C) through a flow sensor (S). The controller operates the air valve actuator (A) to regulate air flow. The airflow setting of the controller is reset by the thermostat (T) in response to the room temperature demand. Minimum and maximum controller airflow rates are adjustable. The controller maintains the flow rate required by the thermostat, independent of upstream pressure fluctuations.

2. Maximum Airflow-Limiting Pressure Independent (single-point PI)

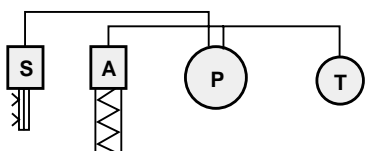

The air flow is sensed by an air pressure switch (P) through a flow sensor (S). The thermostat (T) controls the air valve actuator (A), which regulates air flow in response to the room temperature demand. The air pressure switch overrides the thermostat to limit the maximum airflow. The maximum airflow setting is adjustable through the air pressure switch. The minimum airflow is manually adjusted.

3. Pressure Dependent

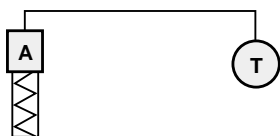

The air valve actuator (A) is controlled directly by the thermostat (T) in response to the room temperature demand. Maximum and minimum airflow (pressure dependent) adjustments are made by manually setting the open and close limit switches. Flow rates may vary due to upstream pressure changes, even if the thermostat does not require a change.

BASIC CONTROL TYPES

1. Pneumatic

Compressed air (20 psig) is used to power a system of modulating controls such as thermostats, actuators, controllers, and various relays. This system is used to provide any number of desired control sequences.

2. Electric

Floating, multi-position air valve control is accomplished by a 24-volt thermostat (single-pole double-throw, center null, bimetal or mercury bulb). This thermostat controls a 24-volt reversible actuator that positions the air valve. Electric relays, air pressure switches, time delays, and cycle timers are used to provide a wide variety of control sequences and functions.

3. Electronic Analog

Modulating control is accomplished by solid state, analog electronic circuitry that senses temperature and air flow. This control package uses a 24-volt reversible actuator to position the air valve, providing a variety of sequences and functions.

4. Electronic, Direct Digital

This type of control is similar to electronic analog, except that inputs and setpoints are interpreted by a digital microprocessor chip, which can be programmed to make complex calculations and decisions. Many DDC controllers also offer optional input &/or output communications with a central Building Automation System.

CONTROL SYSTEM OPTIONS

- Cooling only
- Cooling with electric reheat
- Cooling with hot water reheat
- Warm-up cycle
- Summer/winter dual temperature setpoints
- Dual minimum airflow
- Constant volume

TYPICAL CONTROL CONFIGURATIONS SINGLE DUCT THROTTLING UNIT

PRESSURE INDEPENDENT — PNEUMATIC*

These controls provide a submaster volume controller whose velocity setpoint is reset between

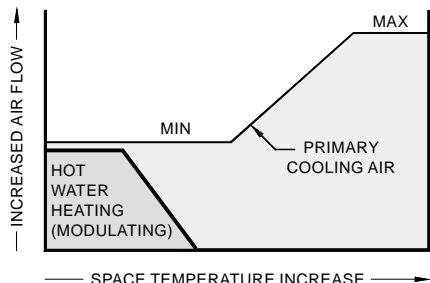

adjustable minimum and maximum limits by the room thermostat master controller. Control sequences can be provided for NO or NC dampers, RA or DA thermostats, and unlimited stages of heat.

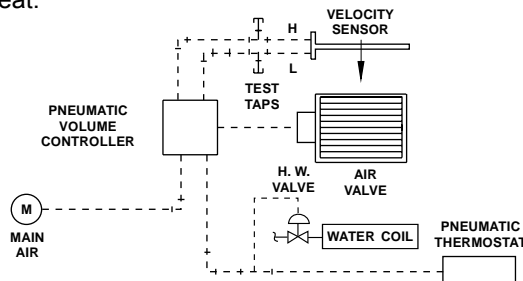

AIRFLOW LIMITING — ELECTRIC*

These controls provide a thermostat as the master controller and an adjustable air pressure switch to limit maximum airflow. The air pressure switch overrides the thermostat when the maximum airflow is reached. Minimum airflow is set

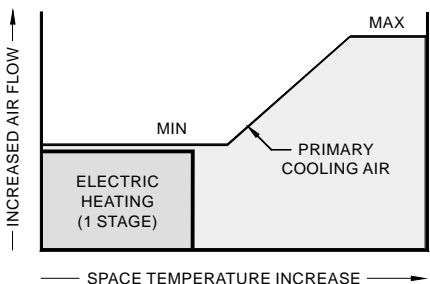

with an end-switch. A cycle timer is included to prevent overshooting.

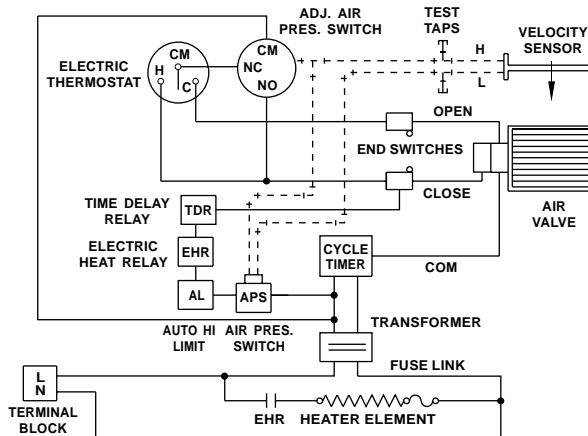

PRESSURE INDEPENDENT — ELECTRONIC*

These controls provide a submaster velocity controller that is reset by the room thermostat master controller. Maximum and minimum CFM limits can be field adjusted at the thermostat. Control sequences can be provided for cooling-only, or cooling with multiple stages of heat.

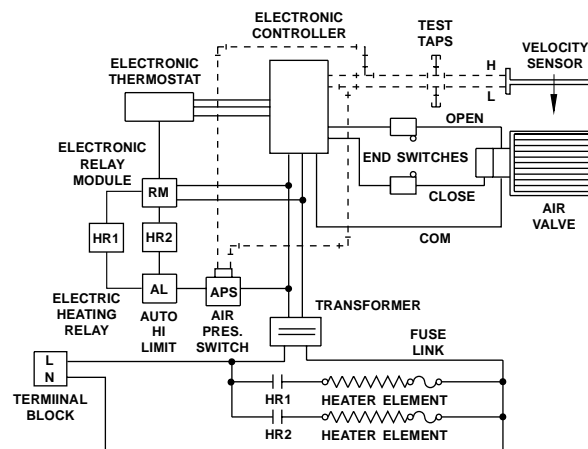
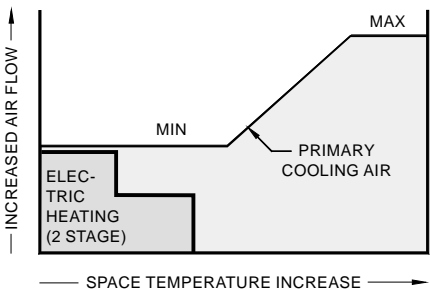

DIRECT DIGITAL CONTROL*

Warren single duct throttling VAV units are also available with Direct Digital Control (DDC).

**For specific control sequences, consult submittal data or the factory.*

SPECIFICATIONS/APPLICATIONS

SINGLE DUCT THROTTLING UNIT

SUGGESTED SPECIFICATIONS

Furnish and install Warren Variable Air Volume Terminal Units (Model ST) of the sizes and capacities shown on the plans.

All assemblies shall be constructed of heavy gauge galvanized steel, with gauges conforming to the requirements of UL 1995. The assemblies shall be so formed and assembled to have the strength and rigidity to withstand normal handling and operational integrity. The assemblies shall be completely and fully lined internally with 1/2" thick, dual density fiberglass insulation or engineered polymer foam insulation (EPFI), per specifications outlined in UL 181 and NFPA 90A. There shall be no cut raw edges of insulation exposed to upstream air flow.

The primary air valve shall be a sliding pleated plate with multiple alternately spaced orifices and with full linear stroke, open to close. Air flow through the valve shall be laminar throughout the open to close cycle. The valve mechanism shall be direct drive, utilizing a pneumatic or 24- VAC bidirectional electric actuator.

Provide electric heat which utilizes the computer selected Calculated Wire Temperature method of element selection to assure optimum VAV performance, or provide hot water coils as scheduled on the plans.

Sound ratings through the primary air valve shall not exceed the discharge and radiated sound-power ratings shown on the schedules.

ACCESSORIES:

- Custom Access Panel
- Perforated Metal Lining
- Multiple Outlet Plenums
- Tedlar Lining
- Foil Lining
- Sound Attenuator

APPLICATIONS

Model STN, STE, and STW Variable Air Volume Terminal Units are designed for use in low, medium, or high pressure single duct variable air volume systems to regulate the flow of air to a room or group of rooms to maintain comfortable temperature levels. The units may be selected for heating only, cooling only, cooling with reheat, ventilation only, or combination heating and cooling applications.

Models STE and STW are designed to provide electric (STE) or hot water (STW) reheating of the primary supply air.

Terminal units are available as system pressure independent or system pressure dependent, controlled by room thermostats that vary the air volume delivered to the space to achieve desired setpoint temperatures. Pressure independent models maintain the desired flow rate (set by the thermostat) regardless of system pressure changes. Dampers on pressure dependent models are controlled directly by the room thermostat.

Since noise criteria (NC) is a major consideration when selecting the required terminal unit, care should be taken to choose the proper size terminal (without oversizing) to obtain optimum controllability.

RECOMMENDED DESIGN NC LEVELS

Offices	
Executive	NC 25-30
Conference Rooms	NC 25-30
Private	NC 30-35
Open-plan Areas	NC 35-40
Business machines/computers	NC 40-45
Lobbies	NC 40-45
Hospitals and Clinics	
Private rooms	NC 25-30
Wards	NC 30-35
Operating rooms	NC 25-30
Laboratories	NC 35-40
Corridors	NC 30-35
Public Areas	NC 35-40
Churches	NC 30-35
Schools	
Lecture and classrooms	NC 25-30
Open-plan classrooms	NC 35-40
Libraries	NC 35-40
Courtrooms	NC 35-40
Playhouse	NC 20-35
Movie theaters	NC 30-35
Restaurants	NC 40-45
Concert and recital halls	NC 15-20
Recording studios	NC 15-20
TV studios	NC 20-25
Private residences	NC 25-30
Apartments	NC 30-35
Hotels/Motels	
Individual rooms or suites	NC 30-35
Meeting/banquet rooms	NC 30-35
Halls, corridors, lobbies	NC 35-40
Service/support areas	NC 40-45

Reference: ASHRAE Handbook — HVAC Applications

INSTALLATION INSTRUCTIONS

SINGLE DUCT THROTTLING UNIT

PACKAGING

All Warren VAV Terminal Units are individually wrapped in a protective polymer cover, and individually boxed or palletized for shipment.

RECEIVING AND INITIAL INSPECTION

Upon receipt, immediately check the contents of cartons or the condition of palletized units. If there is any damage, file a damage claim per the instruction card in each package, and notify Warren **immediately**.

HANDLING AND STORAGE

To avoid damage to controls, wiring, or tubing, always lift terminal units from the bottom. Units should be stored in an upright position with the protective cover in place. Do not stack. Units should never be stored outdoors or in areas affected by inclement weather or construction debris.

CODES

All Warren products must be installed by licensed, qualified contractors. All equipment must be installed and wired in compliance with all applicable local code requirements. All units must be installed with adequate service access.

INSTALLATION PRECAUTIONS

All equipment must be installed and wired in accordance with Warren installation instructions.

Thoroughly check that construction debris has not entered the terminal unit or its intended ductwork. Construction debris may seriously damage or adversely affect the operation of this equipment. Never operate terminal units without the proper filters in place. Units should not be used for temporary heat or allowed to operate before completing factory recommended checkout procedure. Checklist and operating data must be recorded and forwarded to the factory to validate warranty.

START-UP

Before start-up of this equipment, carefully check factory and required field wiring against approved schematic furnished by Warren.

REPAIRS

Any field repairs, modifications, or troubleshooting expenses are solely the responsibility of the purchaser unless written authorization is obtained from the factory. No back charges or costs to Warren will be honored unless a pre-determined work authorization agreement is issued by Warren.

LIMITED WARRANTY

All Warren products are covered by standard limited warranties, provided that the equipment has been properly installed and that all warranty registration documents have been completed and returned to the factory.

METRIC / S.I. CONVERSION FACTORS

(multiply metric value by factor to get Imperial units)

Length:	1 mm	=	0.0394 in.	Air pressure:	1 kPa	=	4.02 in. H ₂ O
Area:	1 m ²	=	10.76 ft ²	Water press:	1 kPa	=	0.335 ft. H ₂ O
Weight:	1 kg	=	2.20 lb.	Velocity:	1 m/sec	=	197 fpm
Density:	1 kg/m ³	=	0.0624 lb/ft ³	Air-flow:	1 m ³ /hr	=	0.588 cfm
Heat:	1 kW	=	3.413 mBh	Air-flow:	1 L/sec	=	2.12 cfm
Temp:	deg. F	=	(9/5 x deg. C) + 32	Water-flow:	1 L/sec	=	15.9 gpm

MODEL CODING SYSTEM
SINGLE DUCT THROTTLING UNIT



WARREN TECHNOLOGY PRODUCTS & SYSTEMS

Warren Technology designs, develops, and manufactures quality products for the heating, ventilation and air-conditioning industry.

Our mission is to provide indoor environmental solutions that enhance personal comfort, improve indoor air quality, and increase energy savings.

Advanced computer-aided design and integrated flexible manufacturing systems developed during the past 35 years enable Warren to respond rapidly to changing customer requirements.

Warren's Uni•VAV® Individual Room Comfort System provides individual temperature control for buildings with almost any type of forced air HVAC system.

Air handling systems for any building, large or small, may be upgraded to achieve greater energy efficiency while providing for the individual temperature needs of each occupant.

The Uni•VAV®, and UNI•GUARD™ systems are designed to improve individual comfort control, productivity and indoor air quality.

UNI•VAV®

- Individual Zone Control
- Energy-Saving Diversification
- System Design Flexibility

Leopard Intellivent®

Personal VAV Diffusers

- Individual Temperature Control
- Easy to Install and Relocate

Valid Air®

High Performance Diffusers

- Increased Air Circulation
- Draft-Free, Dump-Proof Air Flow

Custombuilt™

Electric Duct Heaters

- Safety Tested, Economical

Quiet Plus®

VAV Terminal Units

- Ultra Quiet Operation
- Precise Control

Zebra®

Precision Air Valves

- Laminar Air Flow
- Low Noise Levels

UNI•GUARD™

Individual Room Filtration System

- Improved IAQ

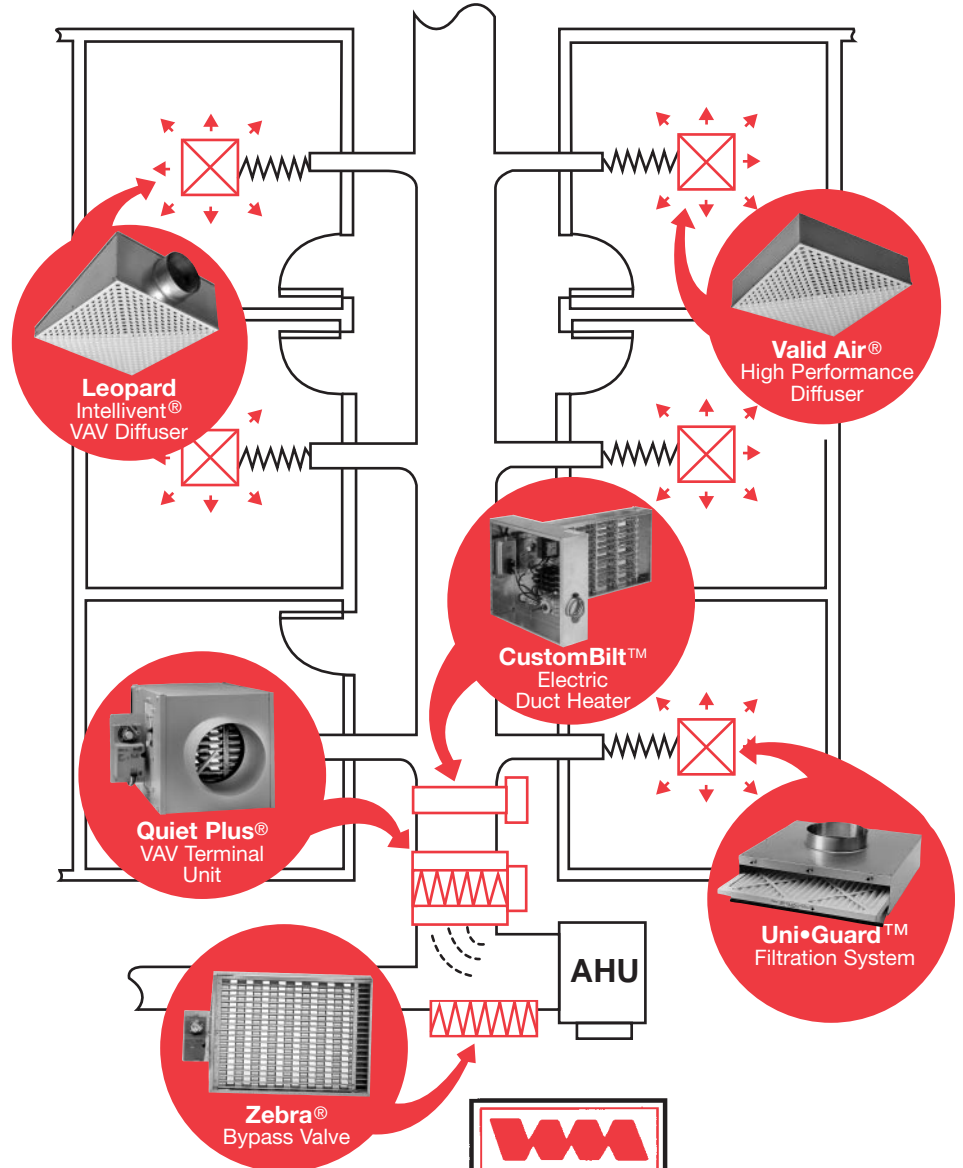

INDOOR ENVIRONMENTAL SOLUTIONS

For more information, call:

1-800-231-1084

2050 W. 73 St., Hialeah, FL 33016-9912

Telephone: (305) 556-6933 • Facsimile: (305) 557-6157

Website: www.warrenhvac.com • E-Mail: warren@warrenhvac.com

