

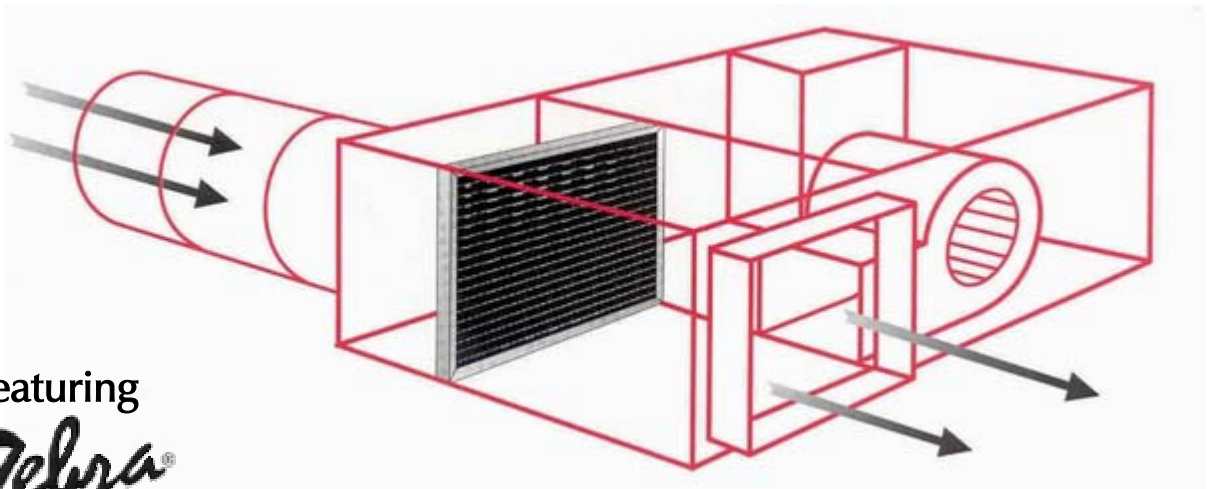

**WARREN**  
TECHNOLOGY

# QUIET PLUS®

VARIABLE AIR VOLUME  
TERMINAL UNITS



Featuring

*Zebra®*

Precision Air Valves

**Model FBI**  
**Intermittent, Fan Powered**  
**Parallel Flow**

Catalog No. FBI-04

**TABLE OF CONTENTS**  
INTERMITTENT FAN POWERED UNIT

**STATEMENT OF PURPOSE**

As an established industry leader in the HVAC market, our philosophy is to add value to the industry by providing quality products and services, and to the community by encouraging participation in its development and progress.

We believe in the application of the Golden Rule to all our business relationships ... with our customers, management and employees, stockholders, sales representatives, suppliers, government, and the community; we believe we have definite obligations to each.

We also believe that our customers are entitled to products and services of the highest quality at a fair price. Our objective is to provide complete customer satisfaction. To assure that we meet this goal in our daily operations, management and employees subscribe to the following guidelines:

***“Engineer, develop, manufacture and market quality products that meet or exceed industry standards.***

***Be a dependable source of supply and effect timely deliveries to meet customer needs.”***

**TABLE OF CONTENTS**

<b>Introduction .....</b>	<b>1</b>
<b>Air Flow Performance Data .....</b>	<b>2</b>
<b>Selection Procedure .....</b>	<b>3</b>
<b>Capacity and Dimensional Data .....</b>	<b>4</b>
<b>Performance Data</b>	
<b>Quick-Select Sound Data .....</b>	<b>5</b>
<b>Discharge Sound Power .....</b>	<b>6</b>
<b>Radiated Sound Power .....</b>	<b>7</b>
<b>Fan Performance Curves .....</b>	<b>8</b>
<b>Electric Heating Coils .....</b>	<b>9</b>
<b>Hot Water Heating Coils .....</b>	<b>10</b>
<b>Controls .....</b>	<b>13</b>
<b>Typical Control Configurations .....</b>	<b>14</b>
<b>Specifications .....</b>	<b>15</b>
<b>Accessories .....</b>	<b>15</b>
<b>Applications .....</b>	<b>16</b>
<b>Installation Instructions .....</b>	<b>16</b>
<b>Model Coding System .....</b>	<b>17</b>

Due to a continuous process of product improvement, specifications &/or designs are subject to change at any time without notice and without incurring obligations.

®Quiet Plus and ®Zebra are registered trademarks of Warren Technology.

## INTRODUCTION

### INTERMITTENT FAN POWERED UNIT

#### **Warren Quiet Plus® VAV Terminal Units**

Variable Air Volume Terminal Units regulate the flow of conditioned supply-air into occupied spaces, to assure that comfortable temperature levels are maintained at much lower energy costs than other types of central systems.

Building owners and designers are aware and concerned about HVAC-system noise levels. Traditionally-designed VAV terminal units are often the most significant factor contributing to a noisy indoor environment. This has a significant impact on occupant comfort and productivity.

Advanced technology and experience have been combined by Warren to create a product line of VAV terminal units which offer a quantum improvement in VAV design and performance. Quiet Plus® VAV terminal units offer ultra-quiet operation plus laminar flow and precision control.

Warren Technology has invested extensively in engineering, product design, and testing in order to provide system designers with accurate flow and acoustic performance data.

Innovative, flexible manufacturing processes governed by modern computer-aided design and manufacturing (CAD/CAM) systems allow Warren to adapt quickly to new design requirements.

#### **Model FBI Bypass-Fan Terminals**

The Quiet Plus® FBI unit feeds VAV supply air alongside an Intermittent-operation discharge-fan, through a common discharge opening. The fan typically cycles on and off with heating demand. The VAV inlet uses the patented Zebra® precision air valve, with superb acoustic performance, laminar flow, and highly accurate control.

Model FBI has 15 sizes, with cooling-inlet capacity from 250–4200 CFM, and heating-fan capacity from 200–2000 CFM. Electronic (analog or DDC), electric, or pneumatic controls with pressure-independent or dependent operation can be specified with many control sequences.

Warren's Electric and Hot Water coils are custom-designed for each application to provide the most reliable, stable operation available.

## AIR FLOW PERFORMANCE DATA INTERMITTENT FAN POWERED UNIT

### CONTROLLABILITY

Warren Quiet Plus VAV Terminal Units have lower sound levels than conventional units. Oversizing to attain acceptable sound levels is unnecessary, so selection may be based on controllability, which ensures maximum performance.

Figure 2 shows the effect of airflow rate and  $\Delta P_s$  on controllability for VAV valves. The maximum operating range of a VAV valve is the physical distance (linear or rotational) in which it modulates. The Effective Operating Range is equal to the maximum operating range minus the amount the valve must close to compensate for the system static pressure at the design airflow rate. Optimum controllability is attained by selecting the smallest sized unit which meets the design airflow and sound requirements.

Effective Operating Ranges of less than 50% are not recommended for VAV terminal units.

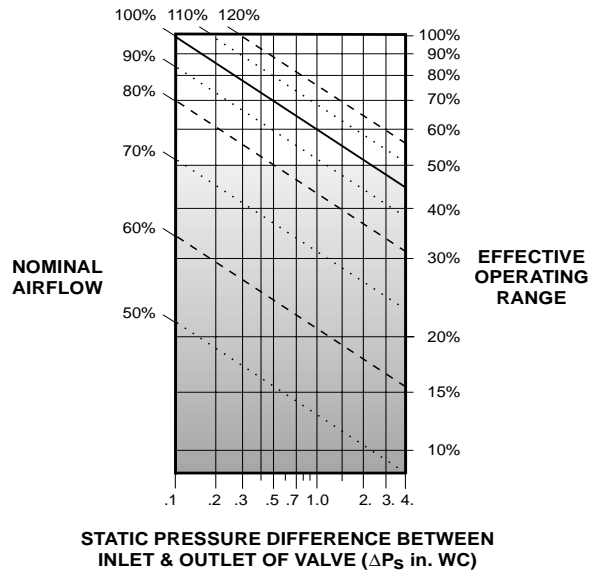

Figure 2. Controllability Graph

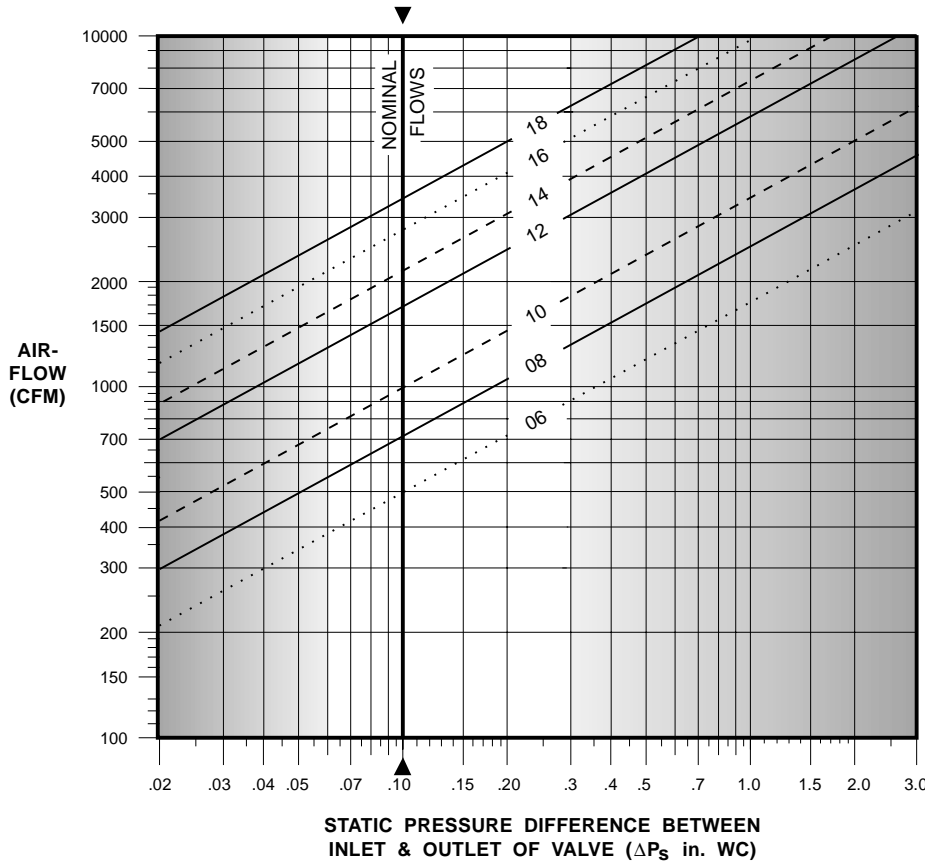

Figure 3. Warren Zebra Valve Airflow Performance Data

### AIR FLOW CAPACITIES

Warren's Quiet Plus VAV Units are offered in a full range of terminal sizes to accommodate most specified airflow requirements.

Figure 3 shows airflow performance data (full open valve) for sizes 06-18 inches, given various static pressure differences between the inlet and outlet of the unit ( $\Delta P_s$ ).

Nominal capacities are based on a  $\Delta P_s$  of 0.10 in. WC, 2000 FPM inlet velocity, 1000 FPM outlet velocity, and 100% effective operating range.

**SELECTION PROCEDURE**  
INTERMITTENT FAN POWERED UNIT

**SELECTION PROCESS**

A. Design data required:

1. Cooling CFM
2. Heating CFM (fan recirculated)
3. Inlet static pressure (ISP)
4. Cooling external duct static pressure loss ( $ESP_C$ ) downstream, not including coil
5. Heating external duct (downstream) static pressure loss ( $ESP_H$ ):

$$ESP_H = ESP_C \times \left[ \frac{\text{Heating CFM}}{\text{Cooling CFM}} \right]^2$$

6.  $\Delta P_s$ : ( $\Delta P_s = ISP - ESP_C$ )
7. Heating requirements in MBH or kW
8. Maximum allowable NC or Sound Power
9. Details about box installation and room, for acoustically-critical cases

B. Establish the model designation (see page 17 for other order-code details):

- FBIN = No Heat  
 FBIE = Electric Heating Coil  
 FBIW = Hot Water Heating Coil

C. Select an inlet size from Table 1 (page 4) that most closely matches the design cooling CFM. *For optimum controllability, select nominal size or smaller. Oversizing will degrade the effective operating range of the unit.*

D. Select a unit with that inlet and a recirculating fan which will deliver the design heating CFM at the heating external duct (downstream) static pressure loss ( $ESP_H$ ), using the fan curves on page 8.

E. If an electric heating coil is required, confirm that the design kW does not exceed the maximum allowable kW using Formula 6 (page 9). Use Tables 8–10 and the Procedure on pages 10–12 to select a hot water heating coil if required, then double-check the fan-curves.

F. Confirm that the unit size selected does not exceed the maximum allowable NC by using Quick-Select Table 2 (page 5) for acoustically non-critical installations, or for critical installations use tables and formulae in Warren's *Acoustic Applications Guide*. If the unit size selected exceeds the maximum allowable NC or Sound Power, then select the next larger unit size and repeat steps D and E.

G. The effective operating range of the unit at the design conditions should be checked using Figure 2 (page 2). Calculate the percentage of nominal airflow using the following formula:

$$\% \text{ of Nominal Airflow} = \frac{\text{Cooling CFM}}{\text{Nominal CFM}} \times 100$$

If the effective operating range of the unit selected falls below 50% on the graph, the next smaller unit should be considered. Re-select, and repeat steps D through F.

**EXAMPLE (Typical Installation)**

A. Given design requirements:

1. Cooling CFM = 1700
2. Heating CFM = 720 (fan recirculated)
3. Inlet static pressure (ISP) = 1.30 in. WC
4. Cooling external duct (downstream) static pressure loss ( $ESP_C$ ) = 0.30 in. WC
5. Heating external duct (downstream) static pressure loss ( $ESP_H$ )

$$ESP_H = .30 \times \left[ \frac{720}{1700} \right]^2$$

$$ESP_H = .05 \text{ in. WC}$$

6.  $\Delta P_s = 1.30 - .30 = 1.0$  in. WC
7. Electric heating coil = 8 kW
8. Maximum allowable NC = 35
9. Installation = not acoustically critical

B. Since the design requires electric heat, the model designation is FBIE.

C. Select FBIEB12M from Table 1 (page 4).

D. Using the fan curve on page 8 for an FBIEB12M, confirm that the fan will deliver 720 CFM at .05 in. WC.

E. Using Formula 6 (page 9), confirm that the required kW does not exceed the maximum allowable ( $720 \text{ CFM} \div 70 = 10.3$  maximum allowable kW; therefore, 8 kW at 720 CFM is acceptable).

F. Quick-Select Table 2 (page 5) indicates that the NC of the selected unit does not exceed the maximum allowable NC 35. For size 12M at 1700 CFM with 1.0"  $\Delta P_s$ , the discharge and radiated NC's are both less than 20.

G. The % of Nominal Airflow =  $1700 \div 1700 = 100\%$ . Checking the effective operating range at 100% for 1.0"  $\Delta P_s$  from Figure 2 (page 2), it is determined that the effective operating range of the unit is 60% (effective operating ranges below 50% are not recommended).

The design requirements can be met with the selection of model FBIEB12M.

**CAPACITY AND DIMENSIONAL DATA**  
INTERMITTENT FAN POWERED UNIT

**Table 1. Model FBI Capacity and Dimensional Data**

Model Number	Inlet Size (in.)	Primary CFM (Nom.)	Primary CFM (Range)	Fan CFM (Range)	Fan HP	Dimensions <sup>⑤</sup>			Outlet		Weight (Est.) <sup>⑥</sup> (lbs.)
						W (in.)	H (in.)	L (in.)	Width (in.)	Height (in.)	
FBI_A06L	6	500	250-700	200-600	1/5	34	10	28	8 <sup>⑧</sup>	8	100
FBI_A08L	8	700	350-900	200-600	1/5	38	10	28	12	8	110
FBI_A10L	10 <sup>⑦</sup>	1000	600-1300	200-600	1/5	42	10	28	16	8	125
FBI_B08M	8	700	350-900	500-800	1/4	38	15	28	12 <sup>⑧</sup>	8	120
FBI_B10M	10	1000	600-1300	500-800	1/4	42	15	28	14 <sup>⑧</sup>	10	130
FBI_B12M	12	1700	1000-2200	500-800	1/4	44	15	28	18	10	135
FBI_C10H	10	1000	600-1300	600-1000	1/3	46	17	32	14 <sup>⑧</sup>	10	160
FBI_C12H	12	1700	1000-2200	600-1000	1/3	48	17	32	18 <sup>⑧</sup>	10	165
FBI_C14H	14	2100	1400-2700	600-1000	1/3	52	17	32	22	14 <sup>⑧</sup>	170
FBI_D12H	12	1700	1000-2200	1200-1600	1/2	48	17	32	18	14 <sup>⑧</sup>	165
FBI_D14H	14	2100	1400-2700	1200-1600	1/2	52	17	32	22	14 <sup>⑧</sup>	170
FBI_D16H	16 <sup>⑦</sup>	2600	1700-3400	1200-1600	1/2	58	17	32	28	14 <sup>⑧</sup>	185
FBI_E14H	14	2100	1400-2700	1400-2000	3/4	52	17	32	22	14 <sup>⑧</sup>	170
FBI_E16H	16 <sup>⑦</sup>	2600	1700-3400	1400-2000	3/4	58	17	32	28	14 <sup>⑧</sup>	185
FBI_E18H	18 <sup>⑦</sup>	3300	2200-4200	1400-2000	3/4	64	17	32	34	14 <sup>⑧</sup>	200

**NOTES:**

- 1) Valve nominal CFM based on maximum 2000 FPM inlet velocity, 1000 FPM outlet velocity, and  $\Delta P_s$  of 0.10 in. WC.
- 2) Fan range CFM based on 0.40 in. WC external static pressure (see Fan Performance Curves on page 8).
- 3) FBIN = No heat FBIE = Electric heat FBIW = Hot water coil.
- 4) FBI units include fan section with motor, fan speed controller, fan relay, backdraft damper, single point wiring, door interlock disconnect switch, lined plenum with slip and drive outlet connection and air valve assembly.
- ⑤ Special controls may increase the size of the control cabinet &/or the unit.
- ⑥ Add 20% to weight for electric heat or 1-row hot water coil; add 30% to weight for 2-row hot water coil.
- ⑦ Oval-inlet dimensions: A10 = 8" x 11<sup>1</sup>/<sub>8</sub>", D16 & E16 = 14" x 17<sup>1</sup>/<sub>8</sub>", E18 = 14" x 20<sup>1</sup>/<sub>4</sub>".
- ⑧ Outlet height increases 1" for hot water coils (14" → 15").
- ⑨ Outlet width increases 2" or 4" for hot water coils (8", 12", 14", & 18" → 10", 16", 16", & 20").

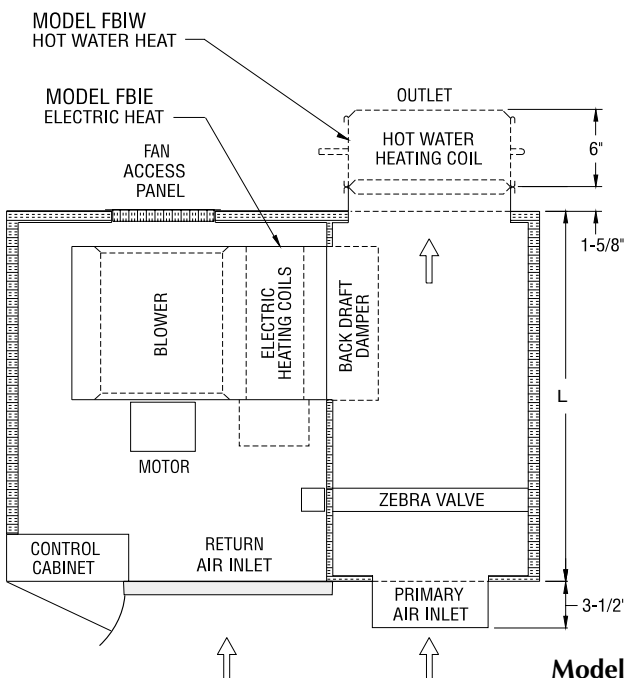

**OCTOPUS OUTLET:** Refer to page 4 of Model DT catalog for diagram and rules for applying this option.

OPTIONAL FILTER AND BRACKET		
Model Number	Filter Width	Filter Height
FBI_A_L	13-3/4"	9-3/4"
FBI_B_M	13-3/4"	14-3/4"
FBI_C_H	17-3/4"	16-3/4"
FBI_D_H	17-3/4"	16-3/4"
FBI_E_H	17-3/4"	16-3/4"

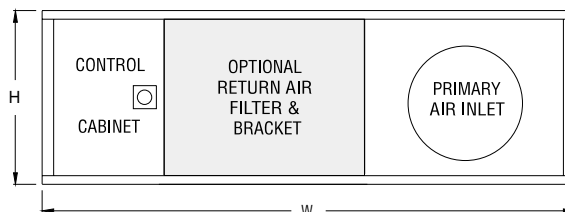

**Model FBI**

**PERFORMANCE DATA**  
INTERMITTENT FAN POWERED UNIT

**Table 2. Model FBI QUICK-SELECT Sound Data, Discharge and Radiated NC Levels**

Inlet Size	CFM	Min $\Delta P_s$	Min $\Delta P_s$		0.5" $\Delta P_s$		1.0" $\Delta P_s$		3.0" $\Delta P_s$	
			Dis	Rad	Dis	Rad	Dis	Rad	Dis	Rad
06	400	.09	-	-	-	-	-	-	-	-
	500	.10	-	-	-	-	-	-	-	-
	600	.15	-	-	-	-	-	-	-	21
08	500	.07	-	-	-	-	-	-	-	-
	700	.13	-	-	-	-	-	-	-	-
	900	.15	-	-	-	-	-	-	-	21
10	800	.07	-	-	-	-	-	-	-	-
	1000	.10	-	-	-	-	-	-	-	-
	1200	.15	-	-	-	-	-	-	20	23
12	1300	.05	-	-	-	-	-	-	-	20
	1700	.10	-	-	-	-	-	-	20	22
	2000	.14	-	-	-	-	-	21	21	25
14	1600	.07	-	-	-	-	-	-	-	-
	2100	.11	-	-	-	-	-	-	-	22
	2600	.15	-	20	-	21	-	21	23	26
16	2000	.05	-	-	-	-	-	-	-	20
	2600	.08	-	-	-	-	-	-	21	23
	3200	.12	-	21	-	22	-	23	24	26
18	2600	.06	-	-	-	-	-	-	22	22
	3300	.10	-	-	-	-	-	21	26	24
	4000	.13	-	23	-	24	20	25	29	28

**PERFORMANCE NOTES:**

- 1) "-" indicates an NC level less than 20.
- 2) " $\Delta P_s$ " is the difference in static pressure from inlet to discharge.
- 3) Test data obtained in accordance with ARI/ADC Test Standard 880.
- 4) Quick-Select NC levels are generated using tables and formulae in Warren's *Acoustic Applications Guide*.
- 5) Discharge NC levels are based on the following:
  - a) 10 dB room absorption
  - b) 5 feet of rectangular lined duct
  - c) 5 feet of standard flex duct
  - d) end reflection
  - e) flow division
- 6) Radiated NC levels are based on the following:
  - a) 10 dB room absorption
  - b) mineral fiber acoustical ceiling tile

**Table 3. Fan Electrical Data**

Fan Size	Motor H.P.	Motor Amperage		
		120 V	208/240 V	277 V
		FLA	FLA	FLA
A	1/5	2.7	1.5	1.8
B	1/4	3.7	2.5	2.2
C	1/3	5.6	3.1	3.0
D	1/2	9.9	4.2	4.1
E	3/4	11.9	5.3	4.5

**PERFORMANCE DATA**  
INTERMITTENT FAN POWERED UNIT

**Table 4. Model FBI DISCHARGE Sound Power in Decibels, Cooling Cycle 100% Primary Air**

		Sound Power Levels, L <sub>w</sub> , re 10 <sup>-12</sup> Watts																												
Inlet Size	CFM	Min ΔP <sub>s</sub>	Min ΔP <sub>s</sub>							0.5" ΔP <sub>s</sub>							1.0" ΔP <sub>s</sub>							3.0" ΔP <sub>s</sub>						
			2	3	4	5	6	7	NC	2	3	4	5	6	7	NC	2	3	4	5	6	7	NC	2	3	4	5	6	7	NC
06	400	.07	40	42	42	39	36	34	-	45	49	53	52	48	46	-	45	50	54	54	53	52	-	50	54	59	61	62	62	-
	500	.10	46	49	49	46	43	40	-	50	55	58	56	54	51	-	50	55	59	59	58	56	-	53	58	62	65	66	66	-
	600	.15	52	56	56	53	50	46	-	55	57	63	60	60	56	-	55	58	64	64	63	60	-	56	60	65	69	70	70	-
08	500	.05	35	38	38	36	33	28	-	42	45	50	49	46	45	-	45	49	54	55	54	53	-	49	53	56	60	61	62	-
	700	.10	43	46	46	44	40	36	-	46	51	55	54	51	53	-	50	53	58	59	57	56	-	52	56	60	64	65	66	-
	900	.15	50	53	53	51	47	44	-	52	56	59	59	56	55	-	53	57	61	62	60	59	-	55	59	64	67	68	69	-
10	800	.07	40	42	43	42	36	34	-	44	48	54	53	51	48	-	49	52	56	58	58	55	-	54	58	64	66	67	67	-
	1000	.10	45	48	50	48	43	40	-	48	53	57	56	54	53	-	52	55	59	62	60	59	-	56	60	65	68	69	69	-
	1200	.15	49	52	54	53	48	45	-	52	55	60	60	58	56	-	55	58	63	65	64	61	-	58	62	67	70	71	71	20
12	1300	.05	39	42	44	41	37	36	-	46	50	56	55	52	51	-	50	54	60	60	59	58	-	57	60	66	69	69	68	-
	1700	.10	47	49	52	49	46	45	-	50	54	60	59	56	55	-	53	57	62	63	62	60	-	60	63	68	70	70	70	20
	2000	.14	52	54	59	55	52	51	-	53	58	63	62	59	57	-	56	59	65	65	64	61	-	61	64	69	73	73	72	21
14	1600	.06	39	42	45	43	39	37	-	49	53	57	56	54	53	-	51	54	59	61	59	59	-	56	59	65	68	69	69	-
	2100	.10	46	48	51	50	46	44	-	52	56	60	59	58	57	-	54	57	64	65	64	62	-	60	63	68	70	70	70	-
	2600	.15	52	55	59	56	53	50	-	55	59	64	63	61	59	-	57	61	67	68	66	65	-	62	65	71	73	74	74	23
16	2000	.05	41	44	47	45	41	39	-	51	54	59	58	56	56	-	53	55	61	63	62	62	-	59	62	68	69	70	70	-
	2600	.08	47	51	55	52	48	46	-	53	58	63	62	60	59	-	56	59	65	66	65	65	-	62	65	69	72	73	73	21
	3200	.12	54	57	60	58	55	53	-	57	62	66	65	64	61	-	60	63	69	70	68	66	-	64	67	73	75	76	76	24
18	2600	.06	42	45	49	47	44	41	-	52	57	61	60	59	58	-	55	58	64	65	63	63	-	61	64	69	72	72	72	22
	3300	.10	50	53	56	54	50	48	-	56	60	65	64	62	61	-	58	61	67	69	67	66	-	63	67	72	74	75	75	26
	4000	.13	56	59	63	60	56	55	-	59	64	68	67	66	64	-	62	65	70	72	70	69	20	66	69	75	77	77	77	29

**Table 5. FAN-ONLY Discharge Sound**

Fan Size	CFM	Octave Band					
		2	3	4	5	6	7
A	200	49	43	37	34	31	30
	400	53	47	41	38	35	34
	600	57	51	45	42	39	38
B	500	52	49	47	44	42	42
	700	56	53	51	48	46	46
	800	58	55	53	50	48	48
C	600	48	46	45	44	43	43
	800	52	50	49	47	46	46
	1000	58	55	54	51	50	50
D	1200	64	55	50	45	43	42
	1400	68	58	53	48	46	46
	1600	70	61	55	50	49	49
E	1400	64	56	49	45	44	44
	1600	68	60	53	48	47	47
	2000	74	70	65	61	59	59

**PERFORMANCE NOTES:**

- 1) Test data obtained in accordance with ARI/ADC Test Standard 880.
- 2) Data is raw, without any corrections for room absorption, duct attenuation, multiple diffuser splits, etc.
- 3) Sound data listed is within ARI tolerances shown in the following table:

Band	2	3	4	5	6	7
Hz	125	250	500	1000	2000	4000
dB	6	4	3	3	3	3

- 4) "ΔP<sub>s</sub>" is the difference in static pressure from inlet to discharge, in. WC.
- 5) "-" indicates an NC level less than 20.
- 6) Discharge NC levels are based on the following:
  - a) 10 dB room absorption
  - b) 5 feet of rectangular lined duct
  - c) 5 feet of standard flex duct
  - d) end reflection
  - e) flow division
- 7) Fan-Only Data is based on external static pressure of 0.40 in. WC.

**PERFORMANCE DATA**  
INTERMITTENT FAN POWERED UNIT

**Table 6. Model FBI RADIATED Sound Power in Decibels, Cooling Cycle 100% Primary Air**

Sound Power Levels, L<sub>w</sub>, re 10<sup>-12</sup> Watts

Inlet Size	CFM	Min ΔP <sub>s</sub>	Min ΔP <sub>s</sub>							0.5" ΔP <sub>s</sub>							1.0" ΔP <sub>s</sub>							3.0" ΔP <sub>s</sub>						
			2	3	4	5	6	7	NC	2	3	4	5	6	7	NC	2	3	4	5	6	7	NC	2	3	4	5	6	7	NC
06	400	.07	30	32	27	21	-	-	-	33	30	34	30	25	-	-	34	33	37	31	27	20	-	38	35	40	41	40	36	-
	500	.10	36	33	36	31	24	-	-	37	35	39	35	30	23	-	38	36	40	36	30	24	-	42	39	44	44	42	39	-
	600	.15	42	38	41	37	32	25	-	43	40	44	39	34	27	-	44	41	46	41	35	28	-	45	43	48	47	45	41	21
08	500	.05	30	26	-	-	-	-	-	34	30	34	30	25	-	-	35	32	37	35	31	26	-	37	35	39	40	39	38	-
	700	.10	34	31	30	24	-	-	-	36	34	38	35	29	22	-	39	35	41	38	33	27	-	42	39	44	44	42	39	-
	900	.15	38	35	39	35	28	20	-	41	38	43	39	33	25	-	43	39	45	41	35	29	-	45	42	46	47	45	41	21
10	800	.07	31	28	24	-	-	-	-	35	33	36	31	24	-	-	39	35	38	36	31	26	-	42	39	44	43	41	39	-
	1000	.10	37	35	35	28	-	-	-	41	37	39	35	28	22	-	42	39	43	39	35	29	-	45	43	46	45	43	41	-
	1200	.15	42	41	41	37	29	-	-	45	42	44	39	32	25	-	46	44	46	44	37	31	-	47	45	50	49	46	42	23
12	1300	.05	37	33	32	-	-	-	-	37	36	38	30	23	-	-	39	37	41	38	34	29	-	45	43	47	45	44	42	20
	1700	.10	43	40	41	34	24	-	-	43	41	43	35	28	22	-	45	42	45	40	37	33	-	48	47	50	48	46	43	22
	2000	.14	46	44	46	40	34	26	-	47	44	47	40	35	27	-	49	45	49	44	39	34	21	51	48	53	50	47	44	25
14	1600	.06	37	33	30	-	-	-	-	36	35	37	31	24	-	-	39	38	41	39	34	28	-	44	43	46	45	43	41	-
	2100	.10	42	39	40	34	24	-	-	42	40	42	37	29	21	-	44	42	45	44	37	32	-	47	46	49	48	45	43	22
	2600	.15	47	45	48	44	36	26	20	47	45	49	45	36	27	21	48	46	49	47	40	34	21	52	50	54	51	48	45	26
16	2000	.05	37	34	31	22	-	-	-	37	37	38	32	25	-	-	42	39	42	40	35	29	-	45	44	47	46	44	42	20
	2600	.08	44	41	40	35	26	-	-	44	42	44	39	30	22	-	45	43	46	44	38	33	-	49	47	50	49	46	44	23
	3200	.12	49	46	49	44	37	28	21	49	47	50	45	37	28	22	50	47	51	48	42	35	23	53	51	54	52	49	46	26
18	2600	.06	39	36	34	25	-	-	-	40	39	40	34	27	-	-	44	42	45	42	37	32	-	46	45	49	48	46	44	22
	3300	.10	45	43	43	37	28	-	-	45	44	46	40	33	25	-	47	45	49	46	41	35	21	52	49	53	50	49	46	24
	4000	.13	51	48	51	46	38	30	23	52	48	51	47	38	31	24	52	50	53	50	44	37	25	55	53	56	54	51	48	28

**Table 7. FAN-ONLY Radiated Sound**

Fan Size	CFM	Octave Band						
		2	3	4	5	6	7	
A	200	58	50	42	42	41	40	
	400	62	54	46	46	45	43	
	600	66	58	50	50	49	47	
B	500	63	57	54	50	45	44	
	700	64	58	56	52	48	47	
	800	68	62	59	56	51	50	
C	600	63	59	51	48	43	41	
	800	66	61	54	50	46	44	
	1000	68	64	59	54	50	48	
D	1200	72	66	62	58	56	53	
	1400	74	69	66	62	60	58	
	1600	75	72	68	65	63	62	
E	1400	72	68	63	58	55	53	
	1600	73	70	65	61	58	56	
	2000	77	73	68	65	63	61	

**PERFORMANCE NOTES:**

- 1) Test data obtained in accordance with ARI/ADC Test Standard 880.
- 2) Data is raw, without any corrections for room absorption, or ceiling effect.
- 3) Sound data listed is within ARI tolerances shown in the following table:

Band	2	3	4	5	6	7
Hz	125	250	500	1000	2000	4000
dB	6	4	3	3	3	3

- 4) "ΔP<sub>s</sub>" is the difference in static pressure from inlet to discharge, in. WC.
- 5) "-" indicates an NC level less than 20.
- 6) Radiated NC levels are based on the following:
  - a) 10 dB room absorption
  - b) mineral fiber acoustical ceiling tile
- 7) Fan-Only data is based on external static pressure of 0.40 in. WC.

**PERFORMANCE DATA**  
INTERMITTENT FAN POWERED UNIT

**Model FBI Fan Performance Curves**

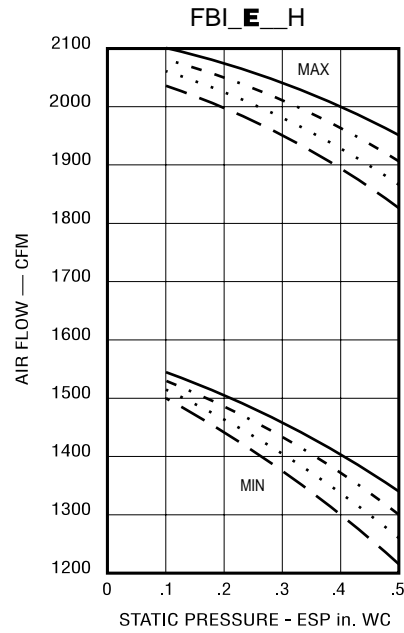
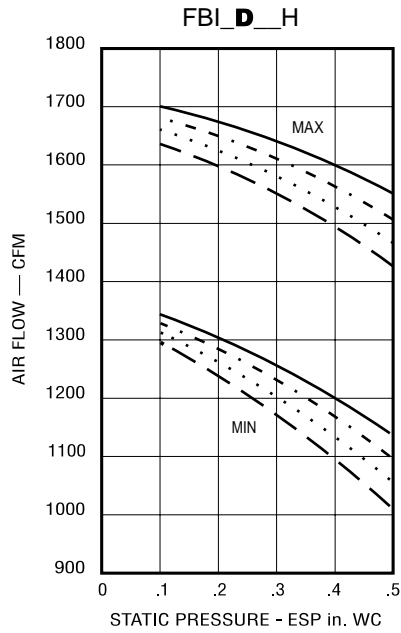
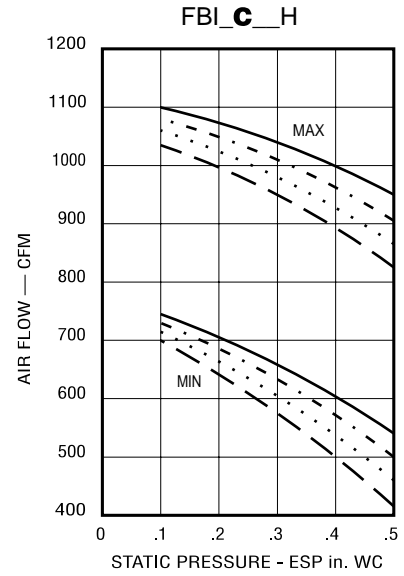
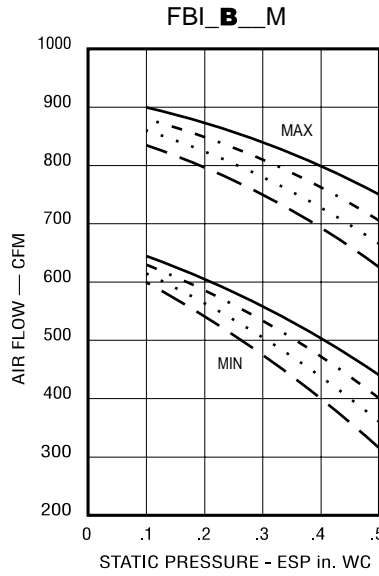
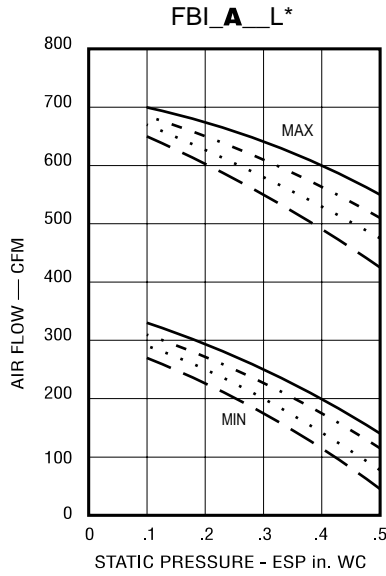

LEGEND		
MODEL	HEAT OPTIONS	LINE TYPE
FBIH	NO HEATING COILS	= —————
FBIE	ELECTRIC HEAT COILS	= - - - - -
FBIW	1 ROW WATER COILS	= ·······
FBIW	2 ROW WATER COILS	= - · - · -

\* MECHANICAL ADJUSTMENT ALLOWS ADDITIONAL REDUCTION OF CAPACITY TO MINIMUM SETTING OF SCR

## ELECTRIC HEATING COILS CONSTANT VOLUME FAN POWERED UNIT

### Standard Heater Features for Terminal Units with Electric Controls:

- Automatic Reset Thermal Cutout
- Backup Thermal Cutout
- De-energizing Magnetic Contactors
- Transformer for 24 Volt Controls
- Power Terminal Block

### Standard Heater Features for Terminal Units with Pneumatic Controls:

- Automatic Reset Thermal Cutout
- Backup Thermal Cutout
- Pneumatic Electric Switches
- Power Terminal Block

### Optional Features:

- Air Flow Switches
- Disconnect Switch
- Magnetic Disconnecting Contactors
- Mercury De-energizing Contactors
- Mercury Disconnecting Contactors
- Fusing
- SCR Controls

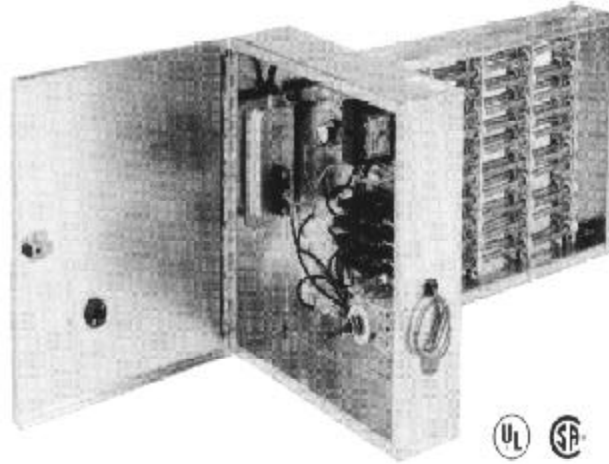

## DESCRIPTION

Warren brings its industry-leading electric heating technology to the Quiet Plus® VAV product line. Computerized design provides maximum versatility and dependability, since exact electrical and heat requirements are achieved. The Zebra® damper's laminar flow assures optimum performance even at low flow settings. Unlike any other coil manufacturer, Warren keeps permanent records for each unit to assure the correct sizing of future replacements.

## ELEMENT DESIGN

Warren's exclusive computerized "Calculated Wire Temperature Method" ensures that the elements never exceed the melting-point of the alloy, even in still, free air. By knowing the exact operating temperature of the elements, the common problems of hot-spots in heaters can be virtually eliminated. This method has resulted in a near-zero failure rate for properly-installed units in the field for over two decades. An infinite number of size and voltage requirements can be handled, to predict exact performance and element life expectancy.

## CONSTRUCTION

Warren's element-support system permits their high-grade refractory ceramic insulators to expand and contract freely without cracking or breaking. Modular design of the frames and boxes using heavy gauge galvanized steel keeps quality high and costs low. One-piece construction of the frame and control box makes installation easy.

## ENGINEERING DATA

### General:

1. Conversion: 1 kW = 3413 BTU/hr
2. Load Req: kW = CFM x °F / 3160
3. Watts = Volts x Amps = Volts<sup>2</sup> / Ohms
4. 1-phase Amps = Watts / Volts
5. 3-phase Amps = Watts / (Volts x 1.73)

### Coil-Specific:

6. Max Allowed kW = Htg CFM / 70
7. Air P in. WC = 0.08 x Htg CFM / Clg CFM

## EXAMPLE

Heating CFM = 850, Cooling CFM = 850,  
Temp Rise = 25°F, Volts/phase = 240V/3ph  
Load Req: 850 CFM x 25°F / 3160 = 6.7 kW  
Current: 6700 W / (240 V x 1.73) = 16.1 A  
Max kW Allowed: 850 CFM / 70 = 12.1 kW  
Pressure Loss: 0.08 x 850 / 850 = 0.08 in. WC

## HOT WATER HEATING COILS INTERMITTENT VOLUME FAN POWERED UNIT

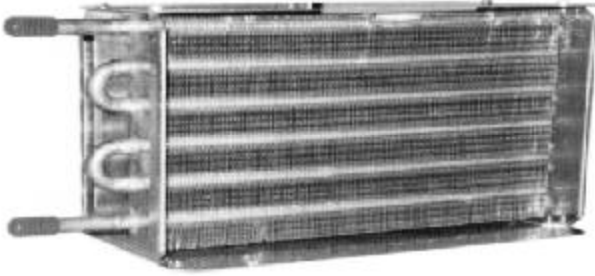

### Standard Features:

- Galvanized Casing
- Slip & Drive Connections
- Aluminum Finned Tubular Construction
- All Copper Tubes
- 1/2" O.D. Male Connections

### SELECTION PROCEDURE FOR HOT WATER COILS:

1. Use the heating CFM and downstream SP (not including HW coil losses) to select a unit size from the fan-curves on page 8, based on two-row coil max-min limits. If a unit cannot be found with a range that includes the CFM/SP point desired, select a unit that can produce somewhat higher SP at the same CFM. Check Figure 2 (pg. 2) for acceptable operating range, and Tables 2–7 (pgs. 5–7) for acceptable acoustic performance.
2. Check the heating-coil data in Table 10 for that unit's size. If the design CFM is within the table's range, check if adequate heating capacity (MBH) &/or airside  $\Delta T$  is available for the application (use corrections from Tables 8–9 below if necessary). Select one-row coils if possible, to reduce SP penalties and cost. If the required CFM or heating capacity is outside the table's range, consider using a different water temperature, or a different unit size.
3. When a unit has been found with adequate heating capacity, a final check of the fan-curves must be done. Add the coil SP-loss from Table 10 to the downstream SP-loss for the application, plus any filtration pressure-losses, and check if that sum (the total fan External Static Pressure) is within the "No Heating Coils" fan curves on page 8. If so, record the waterside GPM and head-loss from Table 10 for the desired MBH heating capacity.

**Table 8. MBH and  $\Delta T$  Correction Factors for Entering Water – Air Temp other than 115°F**

$$\text{Correction Factor} = (\text{Entering Water Temp} - \text{Entering Air Temp}) / 115^\circ\text{F}$$

<i>Ent'g H<sub>2</sub>O-Air °F</i>	65	75	85	95	105	115	125	135	145	155
<b>Correction Factor</b>	0.57	0.65	0.74	0.83	0.91	1.00	1.09	1.17	1.26	1.35

**Table 9. CFM Correction Factors for Air Density other than Sea Level at 70°F**

$$\text{Correction Factor} = 0.0564 \times (460 + \text{Deg. F}) / [29.9 - (0.000956 \times \text{Feet})]$$

<i>Elevation (feet)</i>		-1000	0	1000	2000	3000	4000	5000	6000	7000	8000
<b>CFM</b>	<b>70°F</b>	0.97	1.00	1.03	1.07	1.11	1.15	1.19	1.24	1.29	1.34
<b>Factor</b>	<b>55°F</b>	0.94	0.97	1.00	1.04	1.07	1.11	1.16	1.20	1.25	1.31

### Notes for Hot-Water Coil Selection Table 10:

1. Tables are based on a 115°F temperature difference between entering water (185°F) and entering air (70°F). CFM values are based on air density entering the coil at Sea Level and 70°F. For other entering water-air temperature differences, multiply the rated MBH and air  $\Delta T$  by a factor from Table 8. For other entering-air conditions, multiply rated CFM by a factor from table 9. *Fan-terminal coils are activated only after the VAV damper has been shut to minimum flow & the fan on. The coil ent air temp is equal to the room temp plus heat-gain (from recsd lights) &/or loss (from cold roof or un-insulated supply ducts) in the ceiling plenum, plus fan heat, minus the cooling effect of minimum-ventilation cold air added by the VAV damper. The combined effect typically results in coil entering air temp's between 65–75°F. Typical HW supply temp's are 170–200°F.*
2. The fins per inch, water circuits and water velocity in each coil have been carefully selected to optimize the unit's performance and general applicability in its CFM range. The highest one-row coil capacity typically overlaps the lowest capacity for the same unit's two-row coil at the same airflow rate. If performance outside the specified CFM or MBH ranges is required, contact the factory for customized selections. *Tables are based on one-row coils with 14 fins/inch and two-row coils with 8 fins/inch. Fins are typically .0055" thick corrugated aluminum on 0.016" thick half-inch copper tubes. Number of circuits ranges from 1 to 6, depending on the application. Header connection pipe sizes vary with number of circuits. These details may vary by application.*
3. Water flow rates (GPM) and head loss (feet of water) columns are based on 1.0, 3.0, 5.0, and 7.0 FPS water-velocity through the coils. GPM varies from one coil to another for a given FPS based on the number of circuits. Head-loss varies based on the total tube-length of the coil and header. If performance outside the specified GPM or ft. H<sub>2</sub>O ranges is required, contact the factory for customized selections. *Selections at water velocities higher than 7 FPS result in significant head-loss increases, with minor increases in capacity. Water velocity selections lower than 1 FPS are in the laminar-flow region, which results in major changes in capacity with minor changes in velocity, making the coil harder to control in a stable fashion.*

## HOT WATER HEATING COILS INTERMITTENT FAN POWERED UNIT

**Table 10. Hot Water Heating Coil Data**

SIZE		AIRSIDE		WATERSIDE				
A06	1 row 1/2" O.D.	Heating CFM	SP loss in. H <sub>2</sub> O	Ft. H <sub>2</sub> O:	0.11	0.70	1.70	3.06
				GPM:	0.6	1.8	2.9	4.1
		200	0.06	MBH:	6.9	8.6	9.1	9.3
	1/2" O.D.	350	0.16	Air ΔT:	32	40	42	43
				MBH:	8.3	10.8	11.6	12.0
				Air ΔT:	22	29	31	32
	1/2" O.D.	500	0.30	MBH:	9.2	12.4	13.4	14.0
				Air ΔT:	17	23	25	26
				Ft. H <sub>2</sub> O:	0.23	1.46	3.55	6.36
	8" h 10" w	2 row 1/2" O.D.	Heating CFM	SP loss in. H <sub>2</sub> O	GPM:	0.6	1.8	2.9
				MBH:	9.3	11.2	11.7	11.9
200			0.08	Air ΔT:	43	52	54	55
1/2" O.D.		350	0.21	MBH:	11.4	14.5	15.4	15.8
				Air ΔT:	30	39	41	42
				MBH:	12.8	16.7	17.9	18.5
1/2" O.D.		500	0.40	Air ΔT:	24	31	33	34

SIZE		AIRSIDE		WATERSIDE				
A08	1 row 1/2" O.D.	Heating CFM	SP loss in. H <sub>2</sub> O	Ft. H <sub>2</sub> O:	0.12	0.79	1.91	3.42
				GPM:	0.6	1.8	2.9	4.1
		250	0.06	MBH:	8.2	10.4	11.0	11.3
	1/2" O.D.	400	0.15	Air ΔT:	31	39	41	42
				MBH:	9.5	12.6	13.6	14.1
				Air ΔT:	22	29	32	33
	1/2" O.D.	550	0.26	MBH:	10.4	14.2	15.4	16.1
				Air ΔT:	18	24	26	27
				Ft. H <sub>2</sub> O:	0.25	1.63	3.95	7.09
	8" h 12" w	2 row 1/2" O.D.	Heating CFM	SP loss in. H <sub>2</sub> O	GPM:	0.6	1.8	2.9
				MBH:	11.0	13.5	14.2	14.6
250			0.08	Air ΔT:	41	50	53	54
1/2" O.D.		400	0.19	MBH:	13.0	16.7	17.8	18.4
				Air ΔT:	30	39	41	43
				MBH:	14.3	19.1	20.5	21.2
1/2" O.D.		550	0.34	Air ΔT:	24	32	35	36

SIZE		AIRSIDE		WATERSIDE				
A10	1 row 1/2" O.D.	Heating CFM	SP loss in. H <sub>2</sub> O	Ft. H <sub>2</sub> O:	0.15	0.95	2.31	4.15
				GPM:	0.6	1.8	2.9	4.1
		300	0.05	MBH:	10.0	12.9	13.8	14.2
	1/2" O.D.	450	0.11	Air ΔT:	31	40	43	44
				MBH:	11.4	15.3	16.6	17.2
				Air ΔT:	24	32	34	36
	1/2" O.D.	600	0.18	MBH:	12.3	17.1	18.6	19.5
				Air ΔT:	19	26	29	30
				Ft. H <sub>2</sub> O:	0.30	1.97	4.76	8.54
	8" h 16" w	2 row 1/2" O.D.	Heating CFM	SP loss in. H <sub>2</sub> O	GPM:	0.6	1.8	2.9
				MBH:	13.2	16.7	17.7	18.2
300			0.07	Air ΔT:	41	52	55	56
1/2" O.D.		450	0.14	MBH:	15.2	20.1	21.6	22.3
				Air ΔT:	31	42	45	46
				MBH:	16.6	22.7	24.5	25.5
1/2" O.D.		600	0.24	Air ΔT:	26	35	38	39

SIZE		AIRSIDE		WATERSIDE				
B08	1 row 1/2" O.D.	Heating CFM	SP loss in. H <sub>2</sub> O	Ft. H <sub>2</sub> O:	0.15	0.95	2.31	4.15
				GPM:	0.60	1.80	2.90	4.10
		500	0.13	MBH:	11.7	16.0	17.3	18.0
	1/2" O.D.	600	0.18	Air ΔT:	21	30	32	33
				MBH:	12.3	17.1	18.7	19.5
				Air ΔT:	19	26	29	30
	1/2" O.D.	700	0.24	MBH:	12.8	18.1	19.8	20.7
				Air ΔT:	17	24	26	28
				Ft. H <sub>2</sub> O:	0.30	1.97	4.76	8.54
	8" h 16" w	2 row 1/2" O.D.	Heating CFM	SP loss in. H <sub>2</sub> O	GPM:	0.60	1.80	2.90
				MBH:	15.7	21.1	22.7	23.4
500			0.17	Air ΔT:	29	39	42	44
1/2" O.D.		600	0.24	MBH:	16.6	22.7	24.5	25.5
				Air ΔT:	26	35	38	39
				MBH:	17.3	24.1	26.2	27.3
1/2" O.D.		700	0.31	Air ΔT:	23	32	35	36

SIZE		AIRSIDE		WATERSIDE				
B10	1 row 1/2" O.D.	Heating CFM	SP loss in. H <sub>2</sub> O	Ft. H <sub>2</sub> O:	0.20	1.29	3.13	5.61
				GPM:	0.60	1.80	2.90	4.10
		550	0.09	MBH:	13.7	19.1	20.8	21.7
	1/2" O.D.	675	0.13	Air ΔT:	23	32	35	37
				MBH:	14.5	20.7	22.7	23.8
				Air ΔT:	20	28	31	33
	1/2" O.D.	800	0.18	MBH:	15.1	22.0	24.3	25.5
				Air ΔT:	18	26	28	30
				Ft. H <sub>2</sub> O:	0.20	1.29	3.13	5.61
	10" h 16" w	2 row 5/8" O.D.	Heating CFM	SP loss in. H <sub>2</sub> O	GPM:	1.20	3.50	5.80
				MBH:	21.7	26.8	28.3	29.0
550			0.12	Air ΔT:	37	45	48	49
5/8" O.D.		675	0.18	MBH:	23.3	29.4	31.2	32.0
				Air ΔT:	32	41	43	44
				MBH:	24.6	31.6	33.7	34.7
5/8" O.D.		800	0.24	Air ΔT:	29	37	39	40

SIZE		AIRSIDE		WATERSIDE				
B12	1 row 5/8" O.D.	Heating CFM	SP loss in. H <sub>2</sub> O	Ft. H <sub>2</sub> O:	0.10	0.67	1.63	2.92
				GPM:	1.20	3.50	5.80	8.10
		600	0.09	MBH:	17.5	22.4	24.0	24.7
	5/8" O.D.	725	0.12	Air ΔT:	27	35	37	38
				MBH:	18.5	24.2	26.0	26.9
				Air ΔT:	24	31	33	35
	5/8" O.D.	850	0.16	MBH:	19.4	25.8	27.8	28.9
				Air ΔT:	21	28	30	32
				Ft. H <sub>2</sub> O:	0.22	1.40	3.40	6.10
	10" h 18" w	2 row 5/8" O.D.	Heating CFM	SP loss in. H <sub>2</sub> O	GPM:	1.20	3.50	5.80
				MBH:	23.6	29.5	31.2	32.0
600			0.12	Air ΔT:	36	46	48	50
5/8" O.D.		725	0.16	MBH:	25.1	32.1	34.1	35.1
				Air ΔT:	32	41	44	45
				MBH:	26.5	34.4	36.7	37.8
5/8" O.D.		850	0.22	Air ΔT:	29	38	40	41

SIZE		AIRSIDE		WATERSIDE				
C10	1 row 5/8" O.D.	Heating CFM	SP loss in. H <sub>2</sub> O	Ft. H <sub>2</sub> O:	0.09	0.62	1.49	2.68
				GPM:	1.20	3.50	5.80	8.10
		600	0.11	MBH:	16.4	21.1	22.6	23.3
	5/8" O.D.	775	0.17	Air ΔT:	25	33	35	36
				MBH:	17.7	23.4	25.2	26.1
				Air ΔT:	21	28	30	31
	5/8" O.D.	950	0.24	MBH:	18.8	25.2	27.3	28.4
				Air ΔT:	18	25	27	28
				Ft. H <sub>2</sub> O:	0.20	1.29	3.13	5.61
	10" h 16" w	2 row 5/8" O.D.	Heating CFM	SP loss in. H <sub>2</sub> O	GPM:	1.20	3.50	5.80
				MBH:	22.4	27.9	29.5	30.3
600			0.14	Air ΔT:	35	43	46	47
5/8" O.D.		775	0.23	MBH:	24.4	31.2	33.2	34.2
				Air ΔT:	29	37	40	41
				MBH:	26.0	33.9	36.3	37.4
5/8" O.D.		950	0.32	Air ΔT:	25	33	36	37

**Ratings for Models C12, C14,  
D12, D14, D16, E14, E16, &  
E18 continued on next page...**

## HOT WATER HEATING COILS INTERMITTENT FAN POWERED UNIT

**Table 10 (cont'd). Hot Water Heating Coil Data**

SIZE		AIRSIDE		WATERSIDE					
C12	10" h 20" w	1 row	Heating CFM	SP loss in. H <sub>2</sub> O	Ft. H <sub>2</sub> O:	0.11	0.73	1.76	3.17
					GPM:	1.20	3.50	5.80	8.10
					MBH:	18.9	24.5	26.2	27.0
		5.6" O.D.	825	0.13	MBH:	20.3	27.0	29.1	30.1
					Air ΔT:	27	35	37	39
					Air ΔT:	23	30	33	34
	1000	0.18	MBH:	21.4	29.0	31.5	32.7		
			Air ΔT:	20	27	29	30		
			Air ΔT:	20	27	29	30		
	5.6" O.D.	2 row	Heating CFM	SP loss in. H <sub>2</sub> O	Ft. H <sub>2</sub> O:	0.23	1.52	3.67	6.58
					GPM:	1.20	3.50	5.80	8.10
					MBH:	25.3	32.1	34.0	34.9
650		0.11	MBH:	27.5	35.7	38.1	39.2		
			Air ΔT:	36	46	49	50		
			Air ΔT:	31	40	43	44		
825	0.17	MBH:	29.1	38.7	41.5	42.9			
		Air ΔT:	27	36	39	40			
		Air ΔT:	27	36	39	40			

SIZE		AIRSIDE		WATERSIDE					
C14	15" h 22" w	1 row	Heating CFM	SP loss in. H <sub>2</sub> O	Ft. H <sub>2</sub> O:	0.19	1.21	2.92	5.24
					GPM:	1.20	3.50	5.80	8.10
					MBH:	24.3	32.0	34.4	35.5
		5.6" O.D.	875	0.06	MBH:	26.1	35.3	38.2	39.6
					Air ΔT:	32	43	46	47
					Air ΔT:	28	38	41	42
	1050	0.08	MBH:	27.5	38.1	41.5	43.2		
			Air ΔT:	24	34	37	38		
			Air ΔT:	24	34	37	38		
	7.6" O.D.	2 row	Heating CFM	SP loss in. H <sub>2</sub> O	Ft. H <sub>2</sub> O:	0.23	1.60	3.94	7.12
					GPM:	1.70	5.20	8.70	12.20
					MBH:	34.2	42.6	44.8	45.8
700		0.05	MBH:	37.3	47.6	50.4	51.7		
			Air ΔT:	45	57	59	61		
			Air ΔT:	40	51	54	55		
875	0.08	MBH:	39.8	51.9	55.2	56.8			
		Air ΔT:	35	46	49	50			
		Air ΔT:	35	46	49	50			

SIZE		AIRSIDE		WATERSIDE					
D12	15" h 18" w	1 row	Heating CFM	SP loss in. H <sub>2</sub> O	Ft. H <sub>2</sub> O:	0.16	1.04	2.51	4.51
					GPM:	1.20	3.50	5.80	8.10
					MBH:	26.0	36.3	39.7	41.4
		5.6" O.D.	1350	0.18	MBH:	26.8	37.9	41.6	43.5
					Air ΔT:	18	26	29	30
					Air ΔT:	17	24	27	28
	1500	0.22	MBH:	27.5	39.4	43.4	45.4		
			Air ΔT:	17	24	27	28		
			Air ΔT:	17	24	27	28		
	7.6" O.D.	2 row	Heating CFM	SP loss in. H <sub>2</sub> O	Ft. H <sub>2</sub> O:	0.20	1.38	3.40	6.14
					GPM:	1.70	5.20	8.70	12.20
					MBH:	38.2	50.2	53.5	55.1
1200		0.19	MBH:	39.6	52.7	56.4	58.2		
			Air ΔT:	30	39	41	43		
			Air ΔT:	27	36	39	40		
1350	0.24	MBH:	40.8	55.0	59.1	61.0			
		Air ΔT:	25	34	37	38			
		Air ΔT:	25	34	37	38			

SIZE		AIRSIDE		WATERSIDE					
D14	15" h 22" w	1 row	Heating CFM	SP loss in. H <sub>2</sub> O	Ft. H <sub>2</sub> O:	0.19	1.21	2.92	5.24
					GPM:	1.20	3.50	5.80	8.10
					MBH:	29.1	41.4	45.4	47.5
		5.6" O.D.	1450	0.14	MBH:	29.9	43.1	47.5	49.7
					Air ΔT:	19	28	30	32
					Air ΔT:	18	26	29	30
	1600	0.17	MBH:	30.6	44.6	49.4	51.8		
			Air ΔT:	18	26	29	30		
			Air ΔT:	18	26	29	30		
	7.6" O.D.	2 row	Heating CFM	SP loss in. H <sub>2</sub> O	Ft. H <sub>2</sub> O:	0.23	1.60	3.94	7.12
					GPM:	1.70	5.20	8.70	12.20
					MBH:	42.6	57.0	61.1	63.1
1300		0.16	MBH:	44.0	59.7	64.2	66.4		
			Air ΔT:	30	41	44	45		
			Air ΔT:	28	38	41	43		
1450	0.19	MBH:	45.3	62.2	67.1	69.4			
		Air ΔT:	26	36	39	40			
		Air ΔT:	26	36	39	40			

SIZE		AIRSIDE		WATERSIDE					
D16	15" h 28" w	1 row	Heating CFM	SP loss in. H <sub>2</sub> O	Ft. H <sub>2</sub> O:	0.22	1.46	3.53	6.33
					GPM:	1.20	3.50	5.80	8.10
					MBH:	32.4	47.1	51.9	54.3
		5.6" O.D.	1500	0.10	MBH:	33.3	49.0	54.2	56.9
					Air ΔT:	21	30	34	35
					Air ΔT:	21	30	34	35
	1650	0.12	MBH:	34.0	50.7	56.4	59.3		
			Air ΔT:	19	29	32	33		
			Air ΔT:	19	29	32	33		
	7.6" O.D.	2 row	Heating CFM	SP loss in. H <sub>2</sub> O	Ft. H <sub>2</sub> O:	0.27	1.93	4.75	8.58
					GPM:	1.70	5.20	8.70	12.20
					MBH:	47.3	64.6	69.4	71.8
1350		0.11	MBH:	48.8	67.6	73.0	75.5		
			Air ΔT:	33	44	48	49		
			Air ΔT:	30	42	45	47		
1500	0.13	MBH:	50.2	70.4	76.2	79.1			
		Air ΔT:	28	40	43	45			
		Air ΔT:	28	40	43	45			

SIZE		AIRSIDE		WATERSIDE					
E14	15" h 22" w	1 row	Heating CFM	SP loss in. H <sub>2</sub> O	Ft. H <sub>2</sub> O:	0.19	1.21	2.92	5.24
					GPM:	1.20	3.50	5.80	8.10
					MBH:	29.6	42.5	46.8	49.0
		5.6" O.D.	1675	0.18	MBH:	30.9	45.3	50.3	52.8
					Air ΔT:	17	25	28	29
					Air ΔT:	15	23	25	27
	1950	0.24	MBH:	31.9	47.7	53.3	56.1		
			Air ΔT:	15	23	25	27		
			Air ΔT:	15	23	25	27		
	7.6" O.D.	2 row	Heating CFM	SP loss in. H <sub>2</sub> O	Ft. H <sub>2</sub> O:	0.23	1.60	3.94	7.12
					GPM:	1.70	5.20	8.70	12.20
					MBH:	43.6	58.9	63.2	65.3
1400		0.18	MBH:	45.9	63.3	68.4	70.9		
			Air ΔT:	29	39	42	43		
			Air ΔT:	25	35	38	39		
1675	0.25	MBH:	47.8	67.2	73.0	75.8			
		Air ΔT:	23	32	35	36			
		Air ΔT:	23	32	35	36			

SIZE		AIRSIDE		WATERSIDE					
E16	15" h 28" w	1 row	Heating CFM	SP loss in. H <sub>2</sub> O	Ft. H <sub>2</sub> O:	0.22	1.46	3.53	6.33
					GPM:	1.20	3.50	5.80	8.10
					MBH:	33.0	48.4	53.5	56.1
		5.6" O.D.	1450	0.09	MBH:	34.4	51.5	57.4	60.4
					Air ΔT:	21	31	34	36
					Air ΔT:	19	28	31	33
	1725	0.13	MBH:	35.5	54.2	60.8	64.2		
			Air ΔT:	17	25	28	30		
			Air ΔT:	17	25	28	30		
	7.6" O.D.	2 row	Heating CFM	SP loss in. H <sub>2</sub> O	Ft. H <sub>2</sub> O:	0.27	1.93	4.75	8.58
					GPM:	1.70	5.20	8.70	12.20
					MBH:	48.3	66.6	71.8	74.3
1450		0.12	MBH:	50.8	71.7	77.8	80.7		
			Air ΔT:	31	43	46	48		
			Air ΔT:	27	39	42	43		
1725	0.17	MBH:	52.8	76.0	83.0	86.4			
		Air ΔT:	25	35	39	40			
		Air ΔT:	25	35	39	40			

SIZE		AIRSIDE		WATERSIDE					
E18	15" h 34" w	1 row	Heating CFM	SP loss in. H <sub>2</sub> O	Ft. H <sub>2</sub> O:	0.16	1.10	2.71	4.9
					GPM:	1.70	5.20	8.70	12.20
					MBH:	40.2	56.7	61.8	64.2
		7.6" O.D.	1500	0.07	MBH:	42.0	60.6	66.5	69.4
					Air ΔT:	25	35	38	40
					Air ΔT:	22	32	35	36
	1775	0.09	MBH:	43.6	64.0	70.6	73.9		
			Air ΔT:	20	29	32	34		
			Air ΔT:	20	29	32	34		
	9.6" O.D.	2 row	Heating CFM	SP loss in. H <sub>2</sub> O	Ft. H <sub>2</sub> O:	0.16	1.10	2.68	4.83
					GPM:	3.50	10.40	17.30	24.20
					MBH:	63.9	79.1	83.2	85.1
1500		0.09	MBH:	68.0	85.5	90.4	92.7		
			Air ΔT:	40	49	52	53		
			Air ΔT:	36	45	47	49		
1775	0.13	MBH:	71.5	91.2	96.8	99.5			
		Air ΔT:	32	41	44	45			
		Air ΔT:	32	41	44	45			

**WARREN QUIET PLUS VAV TERMINAL UNITS**

**BASIC CONTROL MODES**

**1. Full-Range Pressure Independent with Max and Min Flow Settings**

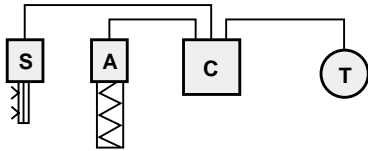

The air flow is sensed by the controller (C) through a flow sensor (S). The controller operates the air valve actuator (A) to regulate air flow. The airflow setting of the controller is reset by the thermostat (T) in response to the room temperature demand. Minimum and maximum controller airflow rates are adjustable. The controller maintains the flow rate required by the thermostat, independent of upstream pressure fluctuations.

**2. Maximum Airflow-Limiting Pressure Independent (single-point PI)**

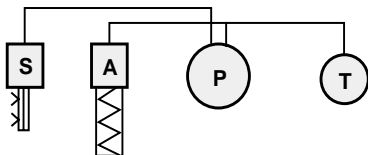

The air flow is sensed by an air pressure switch (P) through a flow sensor (S). The thermostat (T) controls the air valve actuator (A), which regulates air flow in response to the room temperature demand. The air pressure switch overrides the thermostat to limit the maximum airflow. The maximum airflow setting is adjustable through the air pressure switch. The minimum airflow is manually adjusted.

**3. Pressure Dependent**



The air valve actuator (A) is controlled directly by the thermostat (T) in response to the room temperature demand. Maximum and minimum airflow (pressure dependent) adjustments are made by manually setting the open and close limit switches. Flow rates may vary due to upstream pressure changes, even if the thermostat does not require a change.

**BASIC CONTROL TYPES**

**1. Pneumatic**

Compressed air (20 psig) is used to power a system of modulating controls such as thermostats, actuators, controllers, and various relays. This system is used to provide any number of desired control sequences.

**2. Electric**

Floating, multi-position air valve control is accomplished by a 24-volt thermostat (single-pole double-throw, center null, bimetal or mercury bulb). This thermostat controls a 24-volt reversible actuator that positions the air valve. Electric relays, air pressure switches, time delays, and cycle timers are used to provide a wide variety of control sequences and functions.

**3. Electronic Analog**

Modulating control is accomplished by solid state, analog electronic circuitry that senses temperature and air flow. This control package uses a 24-volt reversible actuator to position the air valve, providing a variety of sequences and functions.

**4. Electronic, Direct Digital**

This type of control is similar to electronic analog, except that inputs and setpoints are interpreted by a digital microprocessor chip, which can be programmed to make complex calculations and decisions. Many DDC controllers also offer optional input &/or output communications with a central Building Automation System.

**CONTROL SYSTEM OPTIONS**

- Cooling with electric heat
- Cooling with hot water heat
- Warm-up cycle
- Summer/winter dual temperature setpoints

## TYPICAL CONTROL CONFIGURATIONS INTERMITTENT FAN POWERED UNIT

### PRESSURE INDEPENDENT — PNEUMATIC\*

These controls provide a submaster volume controller whose velocity setpoint is reset between adjustable minimum and maximum limits by the

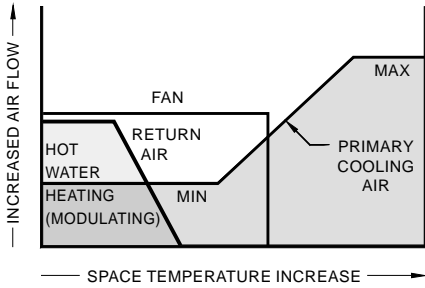

room thermostat master controller. Control sequences can be provided for NO or NC dampers, RA or DA thermostats, and unlimited stages of heat.

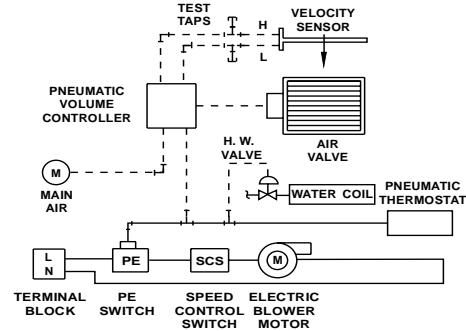

### AIRFLOW LIMITING — ELECTRIC\*

These controls provide a thermostat as the master controller and an adjustable air pressure switch to limit maximum airflow. The air pressure switch overrides the thermostat when the maximum airflow is reached. Minimum airflow is set

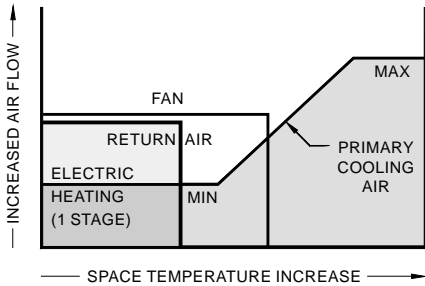

with an end-switch. A cycle timer is included to prevent overshooting.

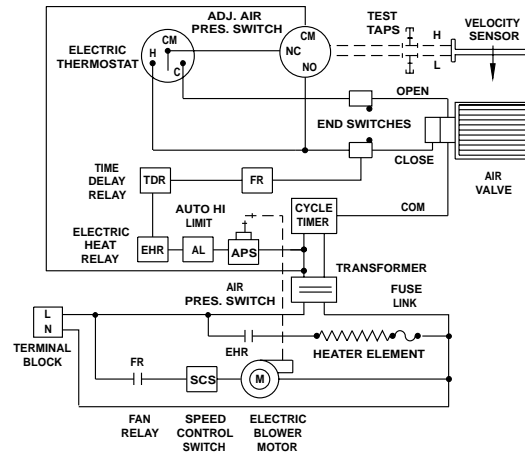

### PRESSURE INDEPENDENT — ELECTRONIC\*

These controls provide a submaster velocity controller that is reset by the room thermostat master controller. Maximum and minimum CFM limits can be field adjusted at the thermostat. Control sequences can be provided for cooling-only, or cooling with multiple stages of heat.

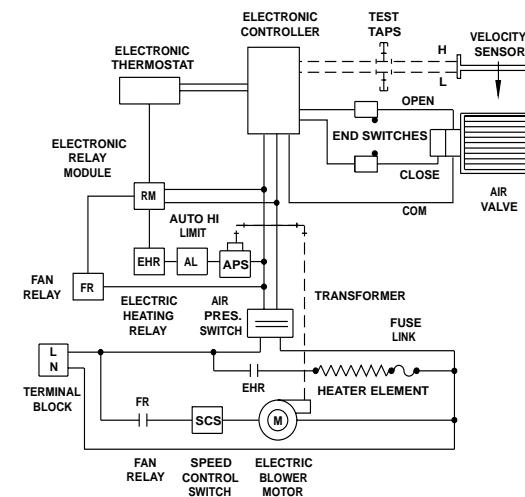
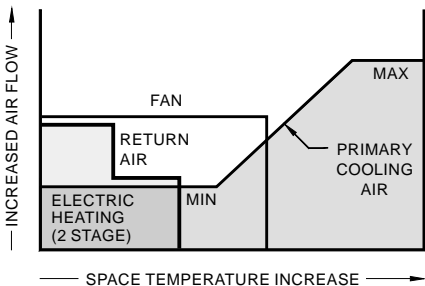

### DIRECT DIGITAL CONTROL\*

Warren intermittent fan powered VAV units are also available with Direct Digital Control (DDC).

*\*For specific control sequences, consult submittal data or the factory.*

**SPECIFICATIONS**  
INTERMITTENT FAN POWERED UNIT

**SUGGESTED SPECIFICATIONS**

Furnish and install Warren Technology intermittent fan powered, parallel flow terminal units (Model FBI) of the sizes and capacities shown on the plan.

The primary air inlets shall be pressure independent and shall reset to any airflow between the minimum and maximum desired air volumes.

The assembly casing shall be constructed of heavy-gauge galvanized steel, with gauges conforming to the requirements of UL 1995. The casing shall be formed and assembled with sufficient strength and rigidity to withstand normal handling and maintain operational integrity. Unit casing shall have removable bottom panel and side access panel to allow removal of fan and servicing of unit.

The assemblies shall be fully lined internally with 1-inch thick, dual density fiberglass insulation per specifications outlined in UL 181 and NFPA 90A. There shall be no cut edges of insulation exposed in the airstream.

The primary air valve shall be a sliding pleated plate with multiple alternately spaced orifices and with full linear stroke, open to close. Air flow through the valve shall be laminar throughout the open to close cycle. The valve mechanism shall be direct drive, utilizing a pneumatic or 24-VAC bidirectional electric actuator.

Electric heat shall be provided as scheduled on the plans utilizing the computer selected Calculated Wire Temperature method of element selection to assure optimum VAV performance, or provide hot water coils as scheduled on the plans.

Sound ratings through the primary air valve and the blower shall not exceed the discharge and radiated sound-power ratings shown on the schedules.

Fan blower shall be constructed of steel with forward curved blades, dynamically balanced wheel and direct drive motor. Motor shall be permanent split capacitor type, with permanently lubricated bearings and thermal overload protection. Motor shall be designed for use with electronic fan speed controller. The blower wheel

and motor assembly shall be internally suspended and isolated from the blower housing on rubber-in-shear isolators to minimize vibration.

A backdraft damper shall be provided at the fan section outlet to prevent cold primary air from flowing back through the fan into the ceiling cavity or return air plenum.

A speed controller shall be provided to allow continuously adjustable fan speed from maximum to minimum. Speed control shall be electronic and shall be matched to operate with the motor. Speed control shall be equipped with a minimum voltage stop to ensure that motor will not operate in the stall mode. Voltage stop shall be factory adjusted.

Units shall incorporate a single point electrical and control connection which shall be provided for the entire assembly. All controls shall be mounted within the unit assembly, sealed from primary air flow. All other electrical components shall be enclosed in a single control box with a hinged access panel mounted on the side of the assembly. The panel shall incorporate a door-mounted disconnect switch. The entire unit shall be ETL listed.

**ACCESSORIES**

- Custom Access Panel
- Tedlar Lining
- Foil Lining
- Perforated Metal Lining
- Sound Attenuator
- Multiple Outlet Plenums
- Variable-Speed Fan (0–10V input)

## APPLICATIONS/INSTALLATION INSTRUCTIONS

### INTERMITTENT FAN POWERED UNIT

#### APPLICATIONS

Intermittent Fan Powered, Parallel Flow Terminal Units are designed for use in low, medium, or high pressure single duct VAV systems that are required to maintain the desired temperature while varying the volume of air during the cooling cycle. The intermittent fan powered terminal unit consists of a variable volume primary air valve section for cooling, and a separate fan section that recirculates warm ceiling plenum air for heating. The ceiling plenum air is induced through the terminal return air opening.

During cooling load operation, the primary air valve varies the volume of air based on space thermostat demand. As the cooling demand decreases, the primary air valve begins closing, reducing the volume of air delivered to the space. At a set point, either when the valve is fully closed, or at a point where the valve remains slightly open for ventilation requirements, the recirculating fan is energized. Heat generated by the building occupants, lights, and various equipment is then induced through the terminal return air opening and delivered to the space via the supply duct. On a further drop in space temperature, the thermostat may energize optional electric or hot water coils to provide additional heat.

#### PACKAGING

All Warren VAV Terminal Units are individually wrapped in a protective polymer cover, and individually boxed or palletized for shipment.

#### RECEIVING AND INITIAL INSPECTION

Upon receipt, immediately check the contents of cartons or the condition of palletized units. If there is any damage, file a damage claim per the instruction card in each package, and notify Warren **immediately**.

#### HANDLING AND STORAGE

To avoid damage to controls, wiring, or tubing, always lift terminal units from the bottom. Units should be stored in an upright position with the protective cover in place. Do not stack. Units should never be stored outdoors or in areas

affected by inclement weather or construction debris.

#### CODES

All Warren products must be installed by licensed, qualified contractors. All equipment must be installed and wired in compliance with all applicable local code requirements. All units must be installed with adequate service access.

#### INSTALLATION PRECAUTIONS

All equipment must be installed and wired in accordance with Warren installation instructions.

Thoroughly check that construction debris has not entered the terminal unit or its intended ductwork. Construction debris may seriously damage or adversely affect the operation of this equipment. Never operate terminal units without the proper filters in place. Units should not be used for temporary heat or allowed to operate before completing factory recommended check-out procedure. Checklist and operating data must be recorded and forwarded to the factory to validate warranty.

#### START-UP

Before start-up of this equipment, carefully check factory and required field wiring against approved schematic furnished by Warren.

#### REPAIRS

Any field repairs, modifications, or troubleshooting expenses are solely the responsibility of the purchaser unless written authorization is obtained from the factory. No back charges or costs to Warren will be honored unless a pre-determined work authorization agreement is issued by Warren.

#### LIMITED WARRANTY

All Warren products are covered by standard limited warranties, provided that the equipment has been properly installed and that all warranty registration documents have been completed and returned to the factory.

**MODEL CODING SYSTEM**  
INTERMITTENT FAN POWERED UNIT



## WARREN TECHNOLOGY PRODUCTS & SYSTEMS

**W**arren Technology designs, develops, and manufactures quality products for the heating, ventilation and air-conditioning industry.

Our mission is to provide indoor environmental solutions that enhance personal comfort, improve indoor air quality, and increase energy savings.

Advanced computer-aided design and integrated flexible manufacturing systems developed during the past 46 years enable Warren to respond rapidly to changing customer requirements.

Warren's Uni•VAV® Individual Room Comfort System provides individual temperature control for buildings with almost any type of forced air HVAC system.

Air handling systems for any building, large or small, may be upgraded to achieve greater energy efficiency while providing for the individual temperature needs of each occupant.

The Uni•VAV®, and UNI•GUARD™ systems are designed to improve individual comfort control, productivity and indoor air quality.

### UNI•VAV®

- Individual Zone Control
- Energy-Saving Diversification
- System Design Flexibility

### Leopard Intellivent®

Personal VAV Diffusers

- Individual Temperature Control
- Easy to Install and Relocate

### Valid Air®

High Performance Diffusers

- Increased Air Circulation
- Draft-Free, Dump-Proof Air Flow

### Custombuilt™

Electric Duct Heaters

- Safety Tested, Economical

### Quiet Plus®

VAV Terminal Units

- Ultra Quiet Operation
- Precise Control

### Zebra®

Precision Air Valves

- Laminar Air Flow
- Low Noise Levels

### UNI•GUARD™

Individual Room Filtration System

- Improved IAQ

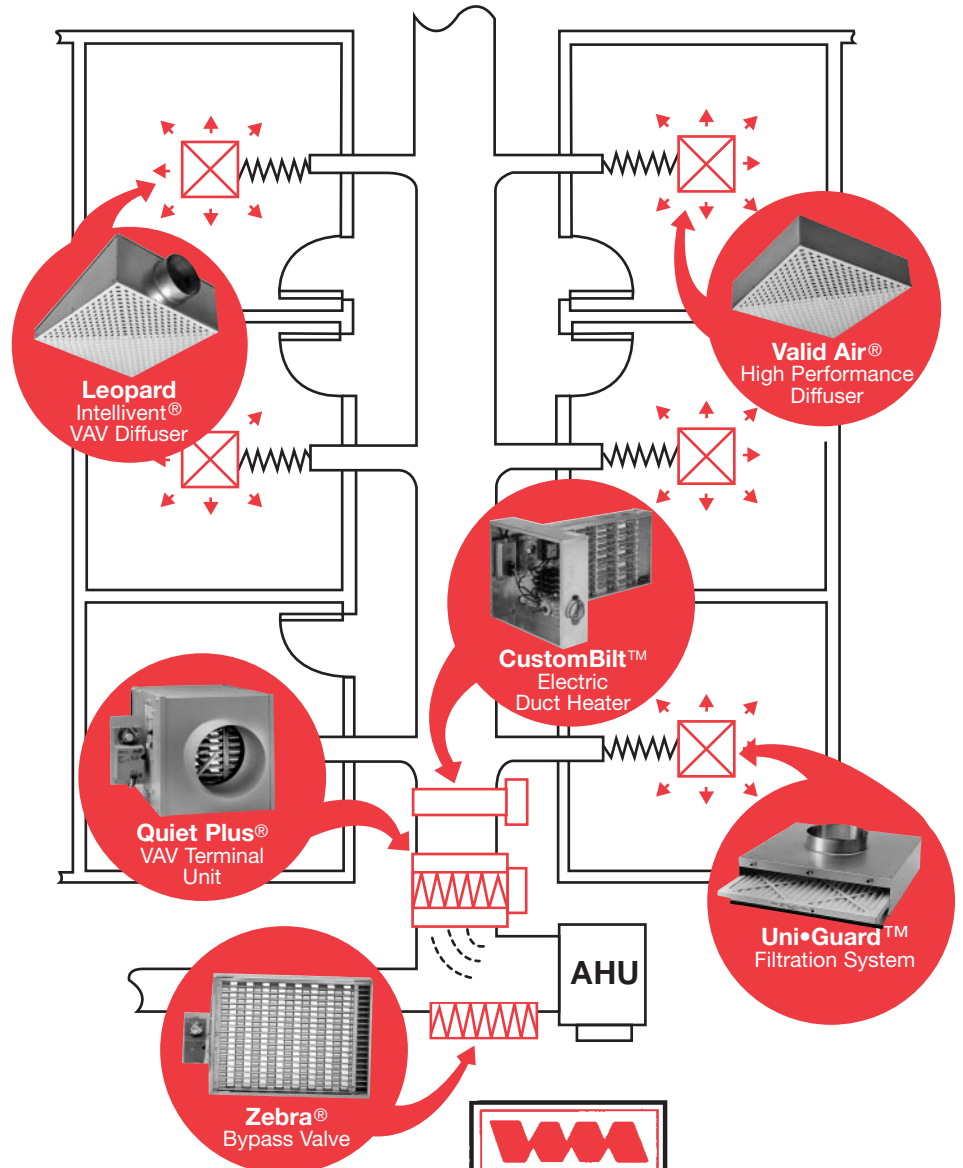

INDOOR ENVIRONMENTAL SOLUTIONS

For more information, call:

1-800-231-1084

2050 W. 73 St., Hialeah, FL 33016-9912

Telephone: (305) 556-6933 • Facsimile: (305) 557-6157

Website: www.warrenhvac.com • E-Mail: warren@warrenhvac.com

